

3745 Communication Controller
All Models

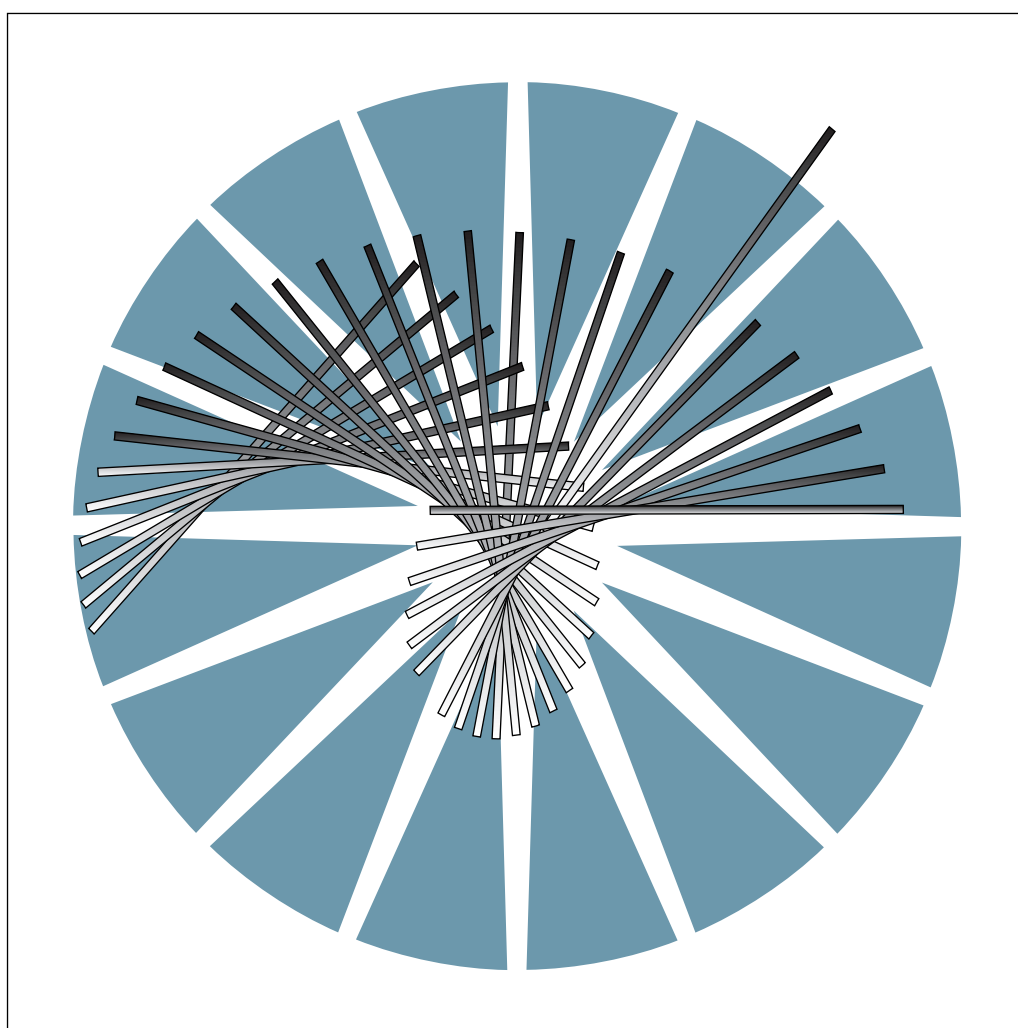

External Cable References



3745 Communication Controller
All Models



External Cable References

Note!

Before using this information and the product it supports, be sure to read the general information under "Notices" on page vii.

Thirteenth Edition (December 1997)

The information contained in this manual is subject to change from time to time. Any such changes will be reported in subsequent revisions. Changes have been made throughout this edition, and this manual should be read in its entirety.

Order publications through your IBM representative or the IBM branch office serving your locality. Publications are not stocked at the address given below.

A form for readers' comments appears at the back of this publication. If the form has been removed, address your comments to:

IBM France
Centre d'Etudes et Recherches
Service 0798 - BP 79
06610 La Gaude
France

- FAX: 33 4 93 24 77 97
- E-mail: FRIBMQF5 at IBMMAIL
- IBM Internal Use: LGERCF at LGEPROFS
- Internet: rcf_lagaude@vnet.ibm.com

When you send information to IBM, you grant IBM a non-exclusive right to use or distribute the information in any way it believes appropriate without incurring any obligation to you.

© **Copyright International Business Machines Corporation 1989, 1997. All rights reserved.**

Note to U.S. Government Users — Documentation related to restricted rights — Use, duplication or disclosure is subject to restrictions set forth in GSA ADP Schedule Contract with IBM Corp.

Contents

Notices	vii
European Union (EU) Statement	vii
Safety Notices for United Kingdom	vii
Electronic Emission Notices	vii
Trademarks and Service Marks	ix
About This Manual	xi
Who Should Use This Manual	xi
How This Manual Is Organized	xi
Where to Find More Information	xi
Summary of Changes	xi
Chapter 1. Console and RSF Interface Cables for All 3745 Models Except Models A	1-1
Cable from the 3745 to a Local Console	1-1
Local Console Cable Wiring	1-1
Local Console Cable Assembly	1-2
Cable from the 3745 to an Alternate Console	1-3
Alternate Console Cable Wiring	1-3
Alternate Console Cable Assembly	1-3
Cable Adapters for a Local/Alternate Console	1-4
Cable Adapter P/N 54F0489 for a 31XX Console	1-4
Cable Adapter P/N 54F0488 for a 3727 Console	1-4
Cable Adapter P/N 54F0490 for a PS/2 or PC Console	1-5
Console Connection through the IBM 7427 Console Switching Unit	1-6
Cables from the 3745 to the 7427 Switching Unit (A)	1-6
Cable Wiring	1-6
Cable Assembly for Local Console	1-6
Cable Assembly for Alternate Console	1-6
Cable from the 7427 to a 31XX or PS/2 or PC Console (B)	1-7
Cable Wiring	1-7
Cable Assembly for a 31XX Console	1-7
Cable Assembly for a PS/2 or PC Console	1-7
Cable from the 7427 to a 3727 Console (B)	1-8
Cable Wiring (B)	1-8
Cable Assembly	1-8
Remote Console Cable	1-9
Cable to Modem for Remote Console	1-9
Cable Wiring	1-9
Cable to Modem for RSF	1-10
RSF Modem Cable	1-10
RSF Modem Cable Wiring	1-11
Console Wrap Tools	1-12
Chapter 2. TSS Interface Cables	2-1
LIC1 through LIC4 Interfaces and Cables	2-1
Ordering DCE/DTE Cables	2-1
LIC Type 1 DCE Interface (Except Japan)	2-2
Interchange Circuits	2-2
Interface Cables	2-3

Adapter Cable	2-3
Wrapping	2-3
Voltage Levels	2-3
LIC Type 1 DCE Interface (Japan NTT Only)	2-4
Interchange Circuits	2-4
Interface Cables	2-5
Test/Operate Switch	2-5
Wrapping	2-6
Voltage Levels	2-6
LIC Type 1 Auto-Call Unit Interface	2-7
Interchange Circuits	2-7
Interface Cables	2-8
To V.25 DCE Autocall Unit U.K. (Adapter PN 674570 Included)	2-8
Adapter Cable	2-9
Wrapping	2-9
Voltage Levels	2-9
LIC Type 1 Direct Attachment Interface	2-10
Interchange Circuits	2-10
Interface Cables	2-11
Wrapping	2-11
Voltage Levels	2-11
LIC Type 3 DCE Interface	2-12
Interchange Circuits	2-12
Interface Cables	2-13
Wrapping	2-13
Voltage Levels	2-13
LIC Type 3 Direct Attachment Interface	2-14
Interchange Circuits	2-14
Interface Cables	2-15
Wrapping	2-15
Voltage Levels	2-15
LIC Type 4A DCE Interface	2-16
Interchange Circuits	2-16
Interface Cables	2-17
Wrapping	2-17
Voltage Levels	2-17
LIC Type 4A Direct Attachment Interface	2-18
Interchange Circuits	2-18
Interface Cables	2-19
Wrapping	2-19
Voltage Levels	2-19
LIC Type 4B DCE Interface	2-20
Interchange Circuits	2-20
Interface Cables	2-21
Wrapping	2-21
Voltage Levels	2-21
LIC Type 4B DCE Interface (France Transfix Only)	2-22
Interchange Circuits	2-22
Interface Cables	2-23
Wrapping	2-23
Voltage Levels	2-23
LIC Type 4B Direct Attachment Interface	2-24
Interchange Circuits	2-24
Interface Cables	2-25

Wrapping	2-25
Voltage Levels	2-25
LIC5 and LIC6 Interfaces and Cables	2-26
LIC Type 5 Line Interface	2-27
Interchange Circuits	2-27
Interface Cables	2-27
Wrapping	2-27
LIC Type 6 Line Interface	2-28
Interchange Circuits	2-28
Interface Cables	2-28
Wrapping	2-28
TSS Wrap Tools	2-29
Wrap Plug PN 65X8927	2-29
Wrap Tool PN 65X8928	2-29
Wrap Plug PN 11F4815	2-30
PKD Interface	2-30
Connector And Pin Assignment	2-30
PT2/3 Interface	2-31
Pin Assignments on Adapter Cable	2-31
Driver/Receiver Typical Voltage Operating Ranges	2-32
3 Volts	2-32
6.5 Volts	2-32
0.55 Volt (V.35 Balanced Circuits)	2-32
Chapter 3. HPTSS Interface Cables	3-1
DTE/DCE Cable Connectors	3-1
V.35 Interface to DCE	3-2
Interchange Circuits	3-2
V.35 Direct Attach Cable	3-3
Cable to DTE	3-3
Interchange Circuits	3-3
X.21 Interface to DCE (Including Transfix France at 1.920Mbps)	3-4
Cable to DCE	3-4
Interchange Circuits	3-4
X.21 Interface to DCE (Transfix France, Except 1.920 Mbps)	3-5
Cable to DCE	3-5
Interchange Circuits	3-5
X.21 Direct Attach Cable	3-6
Cable to DTE	3-6
Interchange Circuits	3-6
EIA-547 Interface to DCE	3-7
Cable to DCE	3-7
Interchange Circuits	3-7
EIA-547 Direct Attach Cable	3-8
Cable to DTE	3-8
Interchange Circuits	3-8
Voltage Interface Measurements	3-9
HPTSS Wrap Plugs	3-10
Wrap Plug V.35 PN 58X9349	3-10
Wrap Plug X.21 PN 58X9354	3-10
Chapter 4. TRSS Interface Cable	4-1
TIC Card to Tailgate Cable	4-1
Interchange Circuits	4-1

Cable to Ring Wall Connector	4-2
Voltage Levels (Ring Transmitter/Receiver)	4-2
Chapter 5. AUI Ethernet Interface Cables	5-1
ESS Wrap Plug PN 70X8670	5-1
Chapter 6. Service Processor Cables for 3745 Models 21A, 31A, 41A, 61A, and 17A	6-1
Cable From any 3745 Model xxA to the 8228	6-2
Interchange Circuits	6-2
Controller Expansion Grounding	6-3
Controller Expansion Unit Power Cables	6-4
Local Area Network Cable	6-5
Interchange Circuit for Standard LAN Cable	6-5
Unshielded Twisted-Pair Cables	6-7
Twisted-Pair Connector Pin Assignment	6-7
Token-Ring UTP Media Filter	6-7
Appendix A. Bibliography	A-1
Customer Documentation for the IBM 3745 (Models 210, 310, 410, 610, 21A, 31A, 41A, and 61A), and 3746 (Model 900)	A-1
Additional Customer Documentation for the IBM 3745 Models 130, 150, 160, 170, and 17A	A-5
Service Documentation for the IBM 3745 (Models 210, 21A, 310, 31A, 410, 41A, 610, and 61A), and 3746 (Model 900)	A-6
Additional Service Documentation for the IBM 3745 Models 130, 150, 160, 170, and 17A	A-10
List of Abbreviations	X-1
Index	X-3

Notices

References in this publication to IBM products, programs, or services do not imply that IBM intends to make these available in all countries in which IBM operates. Any reference to an IBM product, program, or service is not intended to state or imply that only IBM's product, program, or service may be used. Any functionally equivalent product, program, or service that does not infringe any of IBM's intellectual property rights may be used instead of the IBM product, program, or service. Evaluation and verification of operation in conjunction with other products, except those expressly designated by IBM, is the user's responsibility.

IBM may have patents or pending patent applications covering subject matter in this document. The furnishing of this document does not give you any license to these patents. You can send license inquiries, in writing, to the IBM Director of Licensing, IBM Corporation, 500 Columbus Avenue, Thornwood, New York 10594, U.S.A.

European Union (EU) Statement

This product is in conformity with the protection requirements of EU Council Directive 89/336/EEC on the approximation of the laws of the Member States relating to electromagnetic compatibility. IBM can not accept responsibility for any failure to satisfy the protection requirements resulting from a non-recommended modification of the product, including the fitting of non-IBM option cards.

Safety Notices for United Kingdom

1. The IBM 3746 Nways Multiprotocol Controller Model 900 is manufactured according to the International Safety Standard EN 60950 and as such is approved in the UK under the General Approval Number NS/G/1234/J/100003 for indirect connection to the public telecommunication network.
2. The network adapter interfaces housed within the IBM 3746 Nways Multiprotocol Controller Model 900 are approved separately, each one having its own independent approval number. These interface adapters, supplied by IBM, do not use or contain excessive voltages. An excessive voltage is one that exceeds 42.4 V peak ac or 60 V dc. They interface with the IBM 3746 Nways Multiprotocol Controller Model 900 using Safety Extra Low Voltages (SELV) only. In order to maintain the separate (independent) approval of the IBM adapters, it is essential that other optional cards, not supplied by IBM, do not use mains voltages or any other excessive voltages. Seek advice from a competent engineer before installing other adapters not supplied by IBM.

Electronic Emission Notices

Federal Communications Commission (FCC) Statement

Note: This equipment has been tested and found to comply with the limits for a Class A digital device, pursuant to Part 15 of the FCC Rules. These limits are designed to provide reasonable protection against harmful interference when the equipment is operated in a commercial environment. This equipment generates, uses, and can radiate radio frequency energy and, if not installed and used in accordance with the instruction manual, may cause harmful interference to radio

communications. Operation of this equipment in a residential area is likely to cause harmful interference, in which case the user will be required to correct the interference at his own expense.

Properly shielded and grounded cables and connectors must be used in order to meet FCC emission limits. IBM is not responsible for any radio or television interference caused by using other than recommended cables and connectors or by unauthorized changes or modifications to this equipment. Unauthorized changes or modifications could void the user's authority to operate the equipment.

This device complies with Part 15 of the FCC Rules. Operation is subject to the following two conditions: (1) this device may not cause harmful interference, and (2) this device must accept any interference received, including interference that may cause undesired operation.

Industry Canada Compliance Statement

This Class A digital apparatus meets all requirements of the Canadian Interference-Causing Equipment Regulations.

Avis de conformité aux normes d'Industrie Canada

Cet appareil numérique de la classe A respecte toutes les exigences du Règlement sur le matériel brouilleur du Canada.

Japanese Voluntary Control Council For Interference (VCCI) Statement

This equipment is in the 1st Class category (information equipment to be used in commercial and/or industrial areas) and conforms to the standards set by the Voluntary Control Council for Interference by Information Technology Equipment aimed at preventing radio interference in commercial and industrial areas.

Consequently, when used in a residential area or in an adjacent area thereto, radio interference may be caused to radios and TV receivers, and so on.

Read the instructions for correct handling.

Korean Communications Statement

Please note that this device has been approved for business purpose with regard to electromagnetic interference. If you find this is not suitable for your use, you may exchange it for a non-business one.

New Zealand Radiocommunications (Radio) Regulations

Attention: This is a Class A product. In a domestic environment this product may cause radio interference in which case the user may be required to take adequate measures.

Trademarks and Service Marks

The following terms, denoted by an asterisk (*), used in this publication, are trademarks or service marks of IBM Corporation in the United States or other countries:

ESCON	PS/2
IBM	RETAIN
Personal System/2	

The following terms, denoted by a double asterisk (**), used in this publication, are trademarks of other companies:

Hayes	Hayes Microcomputer Products, Inc.
-------	------------------------------------

About This Manual

Who Should Use This Manual

This manual provides references to wrap plugs, console cables, and telecommunication interface cables used to connect any model of IBM® 3745 to external consoles and telecommunication lines.

This manual is dedicated to managers and planners who intend to install the IBM 3745 communication controller. This manual is also useful to all those who will prepare the site for the setup of the controller, or during setup.

How This Manual Is Organized

- | | |
|------------------|--|
| Chapter 1 | Presents the cables used to connect the 3745 to the consoles (local, alternate, remote) and to the RSF modem. |
| Chapter 2 | Presents the different TSS interfaces and the cables used to connect the LICs to the network. The LIC wrap tools, the PKD and PT2/3 interfaces are also described in that chapter. |
| Chapter 3 | Presents the HPTSS interfaces and cables used to connect the high-speed transmission subsystem to the network. HPTSS wrap tools are also described in that chapter. |
| Chapter 4 | Presents the token-ring subsystem interface and cables used to connect the TRSS to the token-ring network. |
| Chapter 5 | Presents the AUI Ethernet interface and cables. |
| Chapter 6 | Presents the service processor cables for 3745 Models xxA. |
-

Where to Find More Information

Service and Customer Bibliographies for all 3745 Models are provided at the end of this manual.

Summary of Changes

All references to external cables connected to the 3746-900 have been removed from this edition. These cables are now referenced in the *3746 Nways Multiprotocol Controller Models 900 and 950 External Cable References*, SY33-2117.

Chapter 1. Console and RSF Interface Cables for All 3745 Models Except Models A

Note: For the console and RSF cables used on any **3745 model A**, go to Chapter 6, "Service Processor Cables for 3745 Models 21A, 31A, 41A, 61A, and 17A" on page 6-1.

Cable from the 3745 to a Local Console

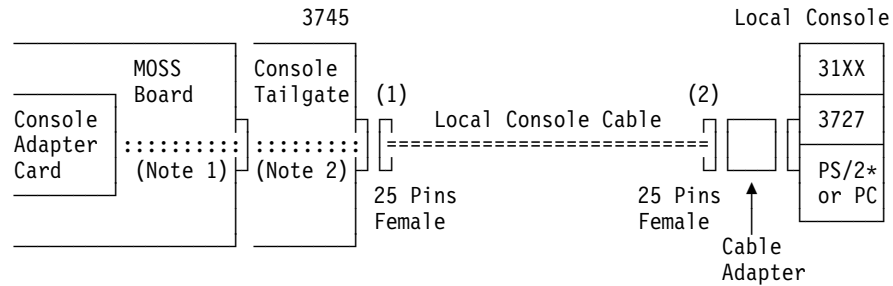

Note 1: Connection is 01A-Y0C5 in 3745 Models 130, 150, 160, and 170
 Connection is 01A-W0C2 in 3745 Models 210, 310, 410, and 610

Note 2: Connection is 01R-A0J3 in 3745 Models 130, 150, 160, and 170

Note 2: Connection is 01R-A0J3 in 3745 Models 130, 150 and 170
 Connection is 01U-B0J4 in 3745 Models 210, 310, 410, and 610

Note: For any **3745 model A**, go to Chapter 6, "Service Processor Cables for 3745 Models 21A, 31A, 41A, 61A, and 17A" on page 6-1.

Local Console Cable Wiring

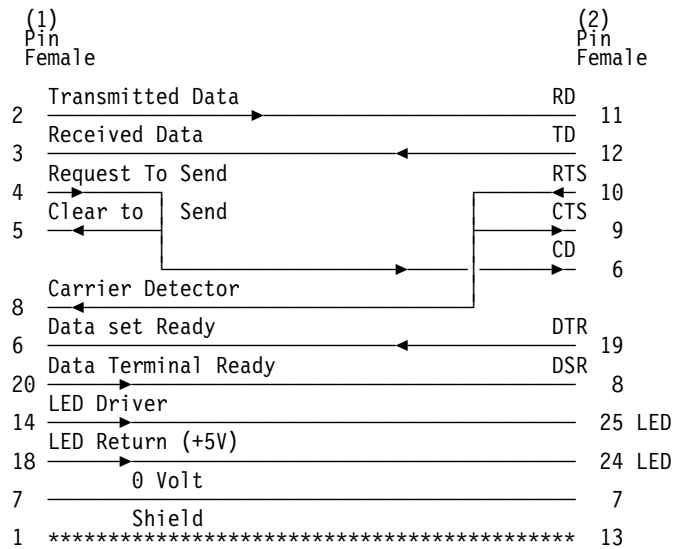

Local Console Cable Assembly

This assembly consists of a local console cable and adapters for a 31XX, 3727, PS/2* or PC (see "Cable Adapters for a Local/Alternate Console" on page 1-4).

World Trade Only

3745 Model	Cable Type	Length, m (ft)	Cable Group	Assembly PN	Cable PN
130/150/160/170	Fixed Length	7 m (23)	Shipped	26F1794	03F4948
210/310/410/610	Fixed Length	7 m (23)	Shipped	26F1792	03F4487

US Only

3745 Model	Cable Type	Length, m (ft)	Cable Group	Assembly PN	Cable PN
130/150/160/170	Fixed Length	7 m (23)	Shipped	76F8600	76F8639
210/310/410/610	Fixed Length	7 m (23)	Shipped	76F8607	76F8640

Cable from the 3745 to an Alternate Console

Note: For any **3745 model A** go to Chapter 6, “Service Processor Cables for 3745 Models 21A, 31A, 41A, 61A, and 17A” on page 6-1.

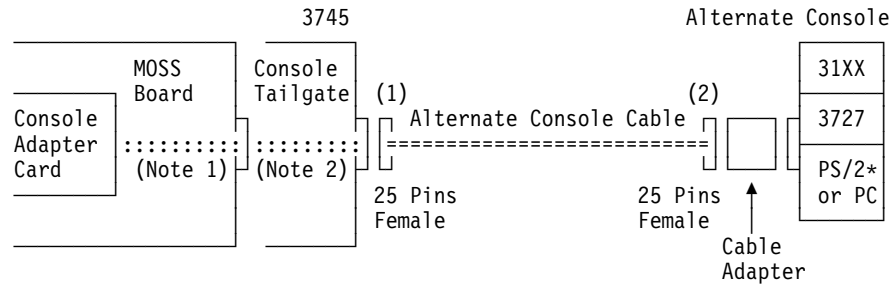

Note 1: Connection is 01A-Y0B5 in 3745 Models 130, 150, 160, and 170
 Connection is 01A-W0B1 in 3745 Models 210, 310, 410, and 610

Note 2: Connection is 01R-A0J2 in 3745 Models 130, 150, 160, and 170
 Connection is 01U-B0J1 in 3745 Models 210, 310, 410, and 610

Alternate Console Cable Wiring

Same as “Local Console Cable Wiring” on page 1-1.

Alternate Console Cable Assembly

This assembly consists of a cable of variable length and adapters for a 31XX, 3727, PS/2 or PC (see “Cable Adapters for a Local/Alternate Console” on page 1-4).

3745 Model	Cable Type	Length, m (ft)	Cable Group	Assembly PN	Cable PN
130/150/160/170	Variable Length	Up to 35 m (115) Up to 122 m (400)	6147 NA	26F1799 26F1799	03F5026 03F5026
210/310/410/610	Variable Length	Up to 35 m (115) Up to 122 m (400)	5826 NA	34F1262 34F1262	65X8984 65X8984

Cable Adapters for a Local/Alternate Console

Note: For any 3745 model A go to Chapter 6, "Service Processor Cables for 3745 Models 21A, 31A, 41A, 61A, and 17A" on page 6-1.

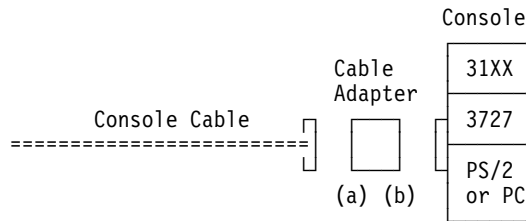

Cable Adapter P/N 54F0489 for a 31XX Console Wiring

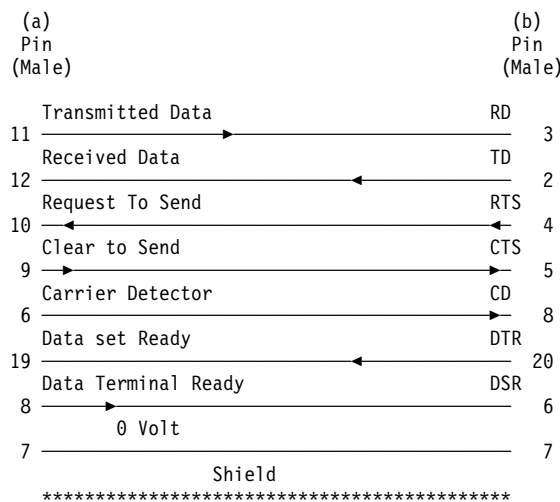

Warning: Use care installing the 31XX adapter as it can be reversed and prevent console operation. Observe the label on the adapter and install as indicated.

Cable Adapter P/N 54F0488 for a 3727 Console Wiring

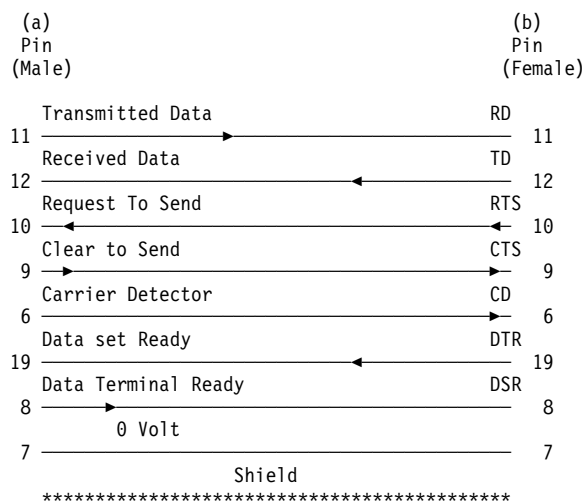

Cable Adapter P/N 54F0490 for a PS/2 or PC Console

Wiring

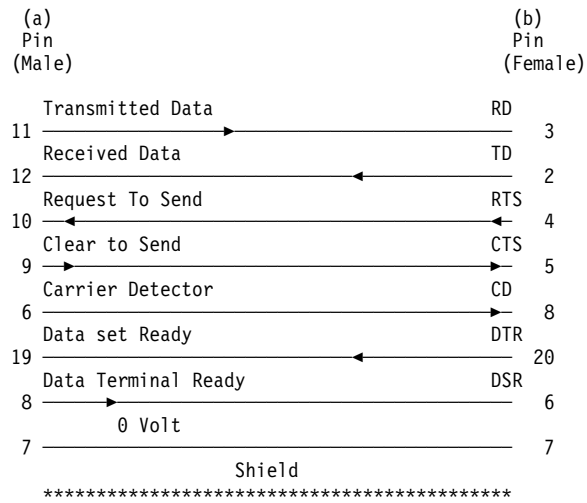

Console Connection through the IBM 7427 Console Switching Unit

Principle: The 7427 is used to switch one console (31XX, 3727, PS/2 or PC) to as many as four 3745s X10 for the local console, or up to six 3745s X10 for the alternate console.

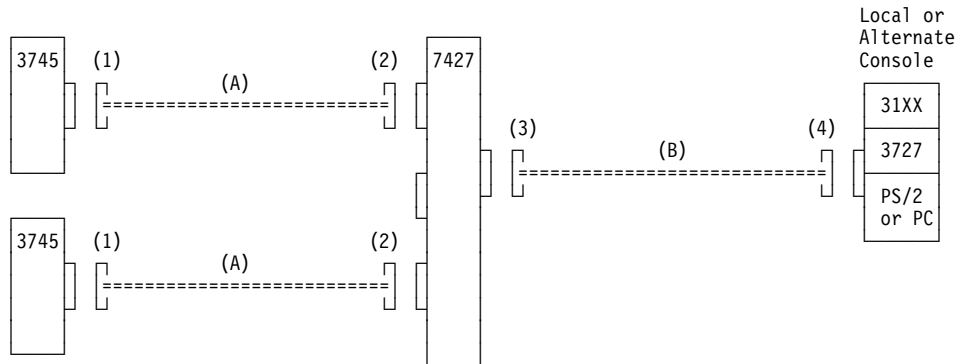

Cables from the 3745 to the 7427 Switching Unit (A)

(These cables are used **with adapters** as local/alternate console cables.)

Cable Wiring

Same as "Local Console Cable Wiring" on page 1-1.

Cable Assembly for Local Console

Same as "Local Console Cable Assembly" on page 1-2.
The cable is connected to the 7427 without an adapter.

Cable Assembly for Alternate Console

Same as "Alternate Console Cable Assembly" on page 1-3.
The cable is connected to the 7427 without an adapter.

Cable from the 7427 to a 31XX or PS/2 or PC Console (B)

Note: For any 3745 model A go to Chapter 6, "Service Processor Cables for 3745 Models 21A, 31A, 41A, 61A, and 17A" on page 6-1.

Cable Wiring

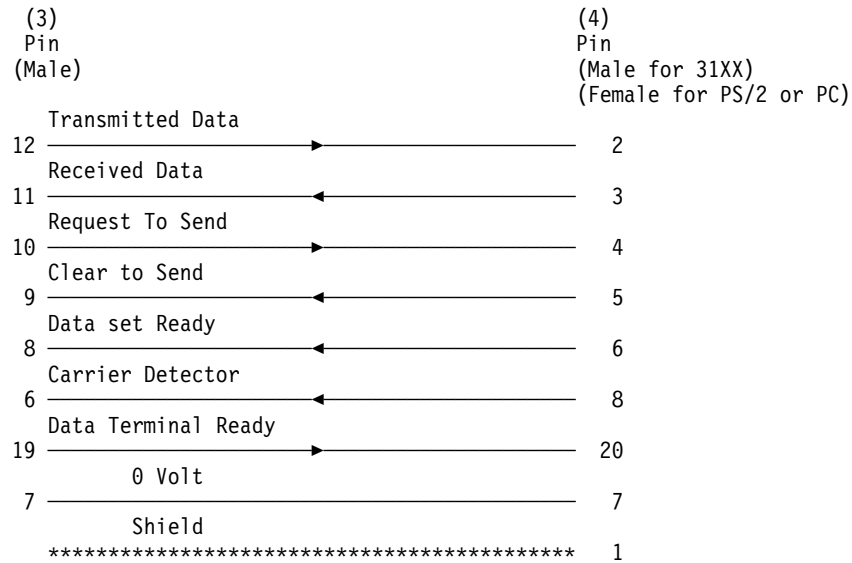

Cable Assembly for a 31XX Console

3745 Model	Cable Type	Length, m (ft)	Cable Group	Cable PN
All Models	Fixed Length	1 m (3)	5828	65X8985

Cable Assembly for a PS/2 or PC Console

3745 Model	Cable Type	Length, m (ft)	Cable Group	Cable PN
All Models	Fixed Length	2 m (6.5)	8148	26F0317

Cable from the 7427 to a 3727 Console (B)

Cable Wiring (B)

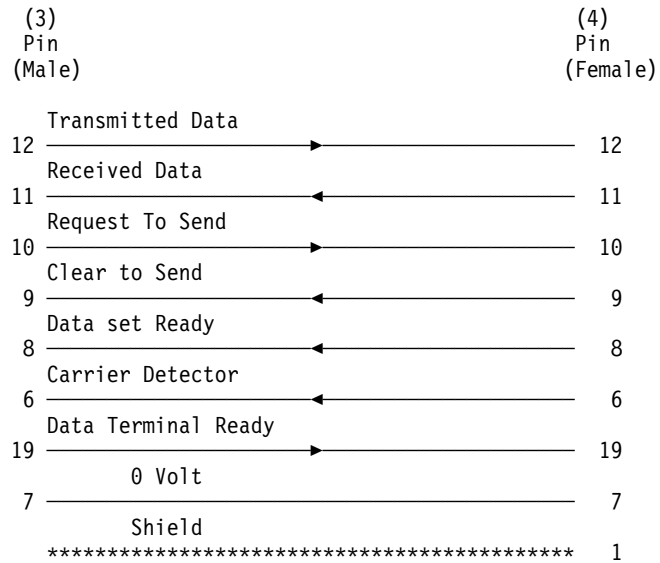

Cable Assembly

This cable for a 3727 console is delivered with the 7427 switching unit.

3745 Model	Cable Type	Length, m (ft)	Cable Group	Cable PN
All Models	Fixed Length	1 m (3)	NA	6081308

Remote Console Cable

Note: For any 3745 model A go to Chapter 6, “Service Processor Cables for 3745 Models 21A, 31A, 41A, 61A, and 17A” on page 6-1.
3745

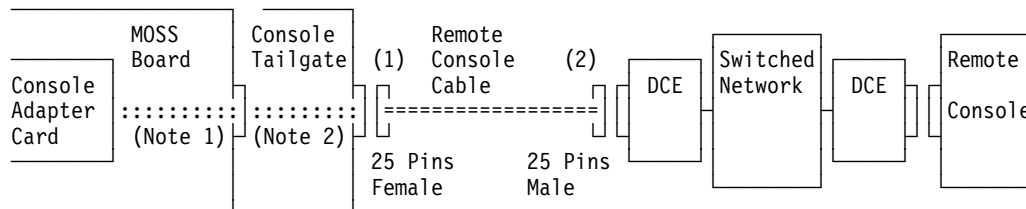

Note 1: Connection is 01A-Y0B5 in 3745 Models 130, 150, 160, and 170
Connection is 01A-W0B1 in 3745 Models 210, 310, 410, and 610

Note 2: Connection is 01R-A0J2 in 3745 Models 130, 150, 160, and 170
Connection is 01U-B0J1 in 3745 Models 210, 310, 410, and 610

Cable to Modem for Remote Console

3745 Model	Cable Type	Length, m (ft)	Cable Group	Cable PN
130/150/160/170	Variable Length	Up to 13.5 m (45) Up to 122 m (400)	6148 NA	03F5027 03F5028
210/310/410/610	Variable Length	Up to 13.5 m (45) Up to 122 m (400)	6153 NA	03F4404 03F4405

Cable Wiring

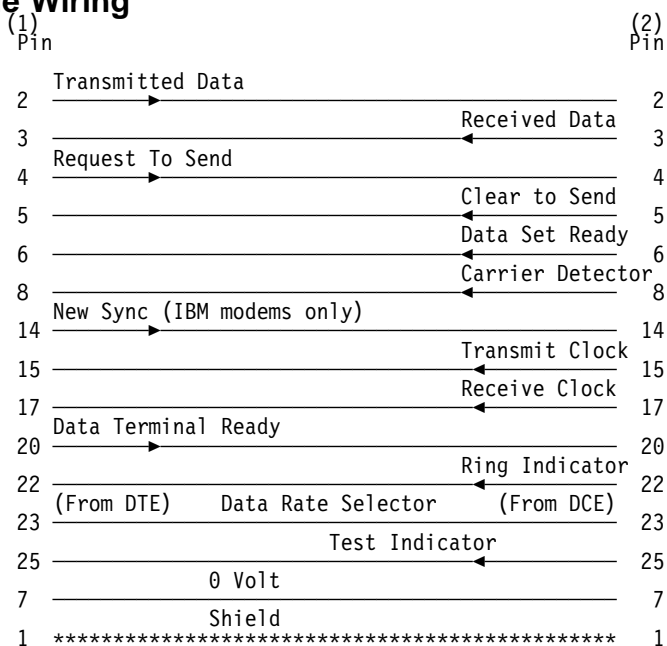

Note: The MOSS microcode monitors data set ready (DSR) and ring indicator (RI) to know whether the remote or the alternate console tries to log on.

- If DSR is up without RI, the alternate console is connected.
- If RI goes up first without DSR, the remote console is calling.

Cable to Modem for RSF

Note: For any **3745 model A** go to Chapter 6, “Service Processor Cables for 3745 Models 21A, 31A, 41A, 61A, and 17A” on page 6-1.

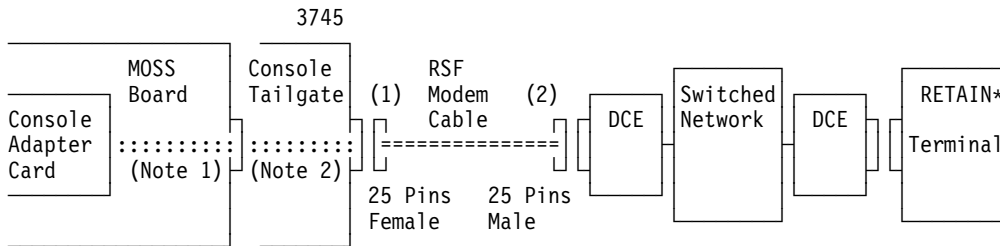

Note 1: Connection is 01A-Y0A5 in 3745 Models 130, 150, 160, and 170
 Connection is 01A-W0C1 in 3745 Models 210 , 310, 410, and 610

Note 2: Connection is 01R-A0J1 in 3745 Models 130, 150, 160, and 170
 Connection is 01U-B0J2 in 3745 Models 210 , 310, 410, and 610

RSF Modem Cable

World Trade Only

3745 Model	Cable Type	Length, m (ft)	Cable Group	Cable PN
130/150/160/170	Fixed Length	13.5 m (45)	Shipped	03F4945
210/310/410/610	Fixed Length	13.5 m (45)	Shipped	65X8920

US Only

3745 Model	Cable Type	Length, m (ft)	Cable Group	Cable PN
130/150/160/170	Fixed Length	13.5 m (45)	Shipped	76F8604
210/310/410/610	Fixed Length	13.5 m (45)	Shipped	76F8611

RSF Modem Cable Wiring

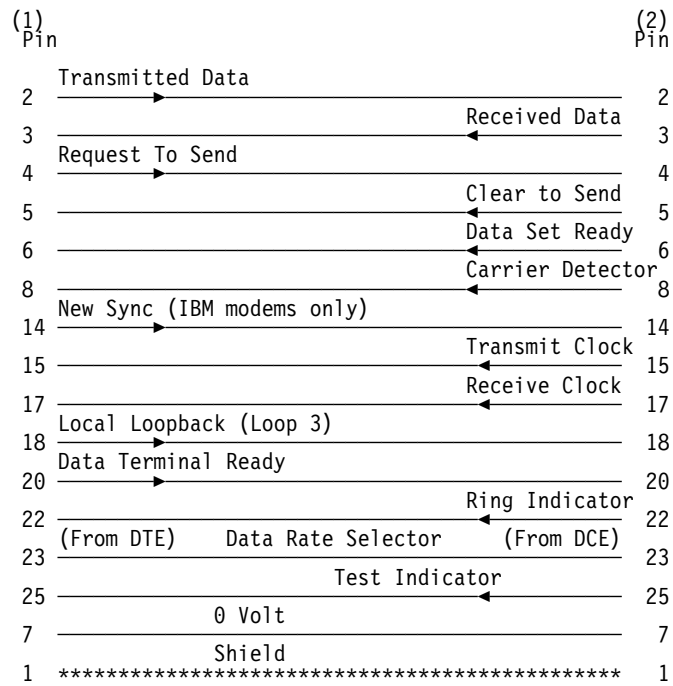

Console Wrap Tools

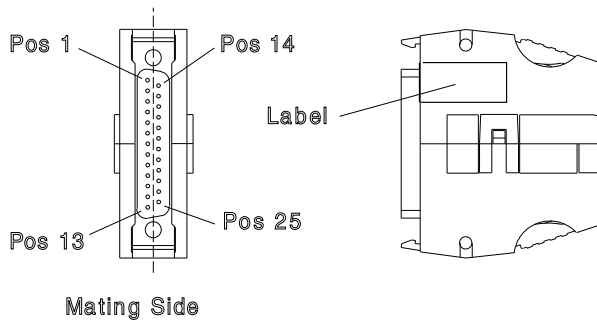

Wrap Tool (P/N 6398697) for Console Tailgate Connectors:

For a console link test, you can install this 25-position wrap socket (female) on any connector of the 3745 console tailgate (local, remote/alternate, RSF).

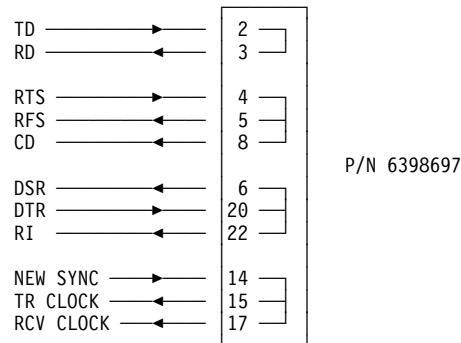

Wrap Tool P/N 02667737 for Local/Alternate/7427 Cable:

For a test of the cable when running a console link test, you can install this 25-pin wrap plug (male) in the connector at the console end of the 3745-to-local/alternate/7427 cable.

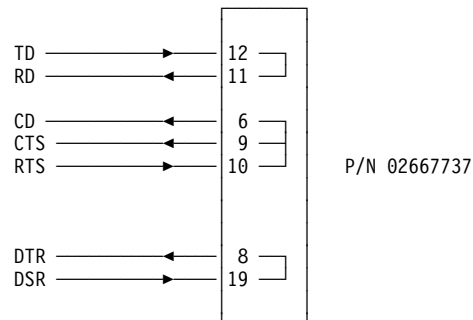

Chapter 2. TSS Interface Cables

LIC1 through LIC4 Interfaces and Cables

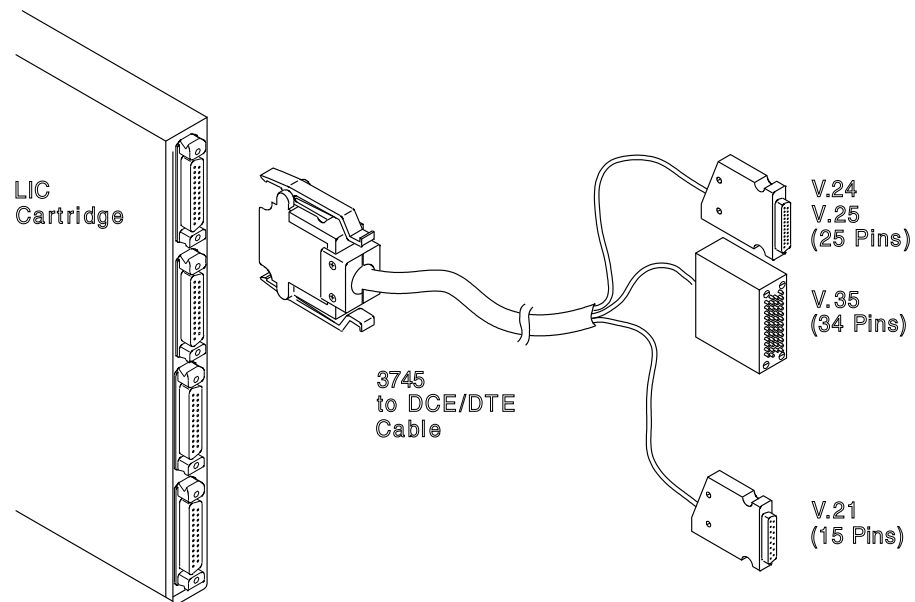

Ordering DCE/DTE Cables

1. For cables less than 13.5 m long, order through cable group.
2. For European, Middle Eastern and African countries (fixed/standard length of 13.5 m) cables, order through BM number.
3. For the U.S.A. (fixed/standard length of 13.5 m) cables, order through cable group.
4. For cables longer than 13.5 m, order through part number.

LIC Type 1 DCE Interface (Except Japan)

Interface	CCITT V.24 (EIA 232C) CCITT X.21 Bis
Transmission speed	Externally clocked up to 19 200 bps
Number of lines	Up to four
Transfer mode	Half-duplex or duplex
Protocols	Start-stop, BSC, SDLC
DTE clocking	Up to 1200 bps for synchronous Up to 19 200 bps for start-stop

Notes:

1. JAPAN NTT: See "LIC Type 1 DCE Interface (Japan NTT Only)" on page 2-4.
2. Belgium: See "Adapter Cable" on page 2-3.
3. Cable identifier bit 1 set to 0 indicates modem function (100-series).
Cable identifier bit 1 set to 1 indicates autocal equipment installed (200-series).

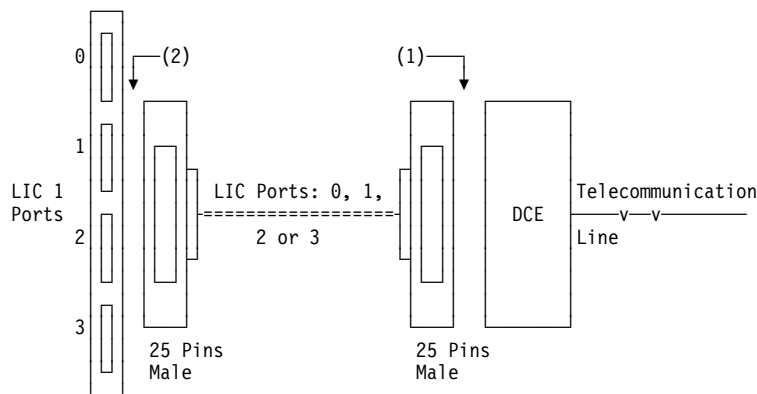

Interchange Circuits

To V.24 DCE (Except Japan NTT)

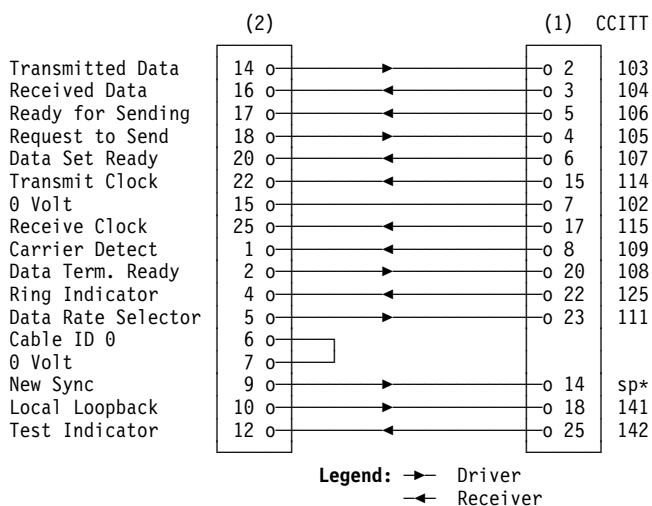

To X.21 Bis DCE (Except Japan NTT)

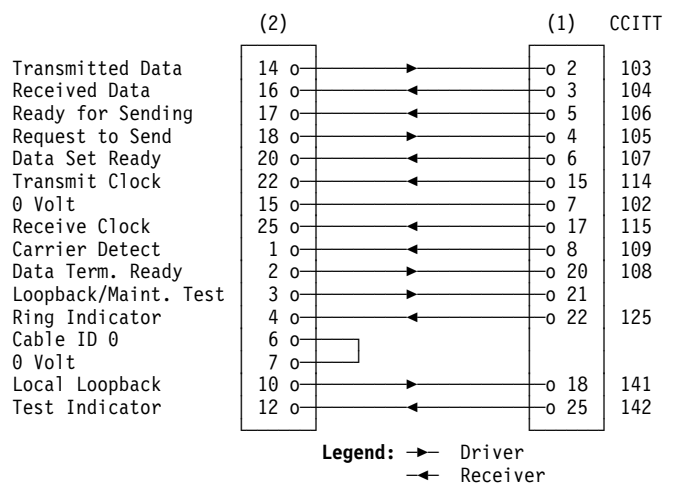

Interface Cables

To V.24 DCE (Except Japan and Belgium)

Cable Type and Length m (ft)	Feature Code	Cable Group	BM Number	Cable PN
Fixed length: 13.5 m (45)	4911 (LIC1)	1604	03F4907	6398643
13.5 m (45) or less		1628	6398643	6398643
More than 13.5 m (45) and up to 100 m (330)		N/A	6398785	6398785

To V.24 DCE Belgium Only (Adapter PN 1743585 Included)

Cable Type and Length m (ft)	Feature Code	Cable Group	BM Number	Cable PN
Fixed length: 13.5 m (45)	4911 (LIC1)	1620	03F4908	65X9520
13.5 m (45) or less		1620	6398672	6398672
More than 13.5 m (45) and up to 100 m (330)		N/A	6398780	6398780

To X.21 Bis DCE (All Countries Except Japan)

Cable Type and Length m (ft)	Feature Code	Cable Group	BM Number	Cable PN
Fixed length: 13.5 m (45)	4911 (LIC1)	8154	61F4508	61F4504
13.5 m (45) or less		8152	61F4504	61F4504
More than 13.5 m (45) and up to 100 m (330)		N/A	61F4506	61F4506

Adapter Cable

To V.24 DCE in Belgium (PN 1489985)

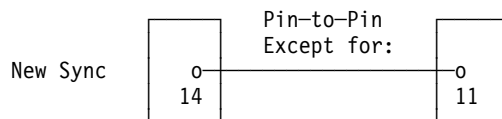

Wrapping

At Cartridge Connector: Install wrap plug PN 65X8927 in (2), ports 0, 1, 2, or 3. See "TSS Wrap Tools" on page 2-29 for pin-to-pin assignment.

Voltage Levels

See "6.5 Volts" on page 2-32.

LIC Type 1 DCE Interface (Japan NTT Only)

Interface	CCITT V.24 (EIA 232C) CCITT X.21 Bis
Transmission speed	Externally clocked up to 19 200 bps
Number of lines	Up to four
Transfer mode	Half-duplex or duplex
Protocols	Start-stop, BSC, SDLC
DTE clocking	Up to 1200 bps for synchronous Up to 19 200 bps for start-stop

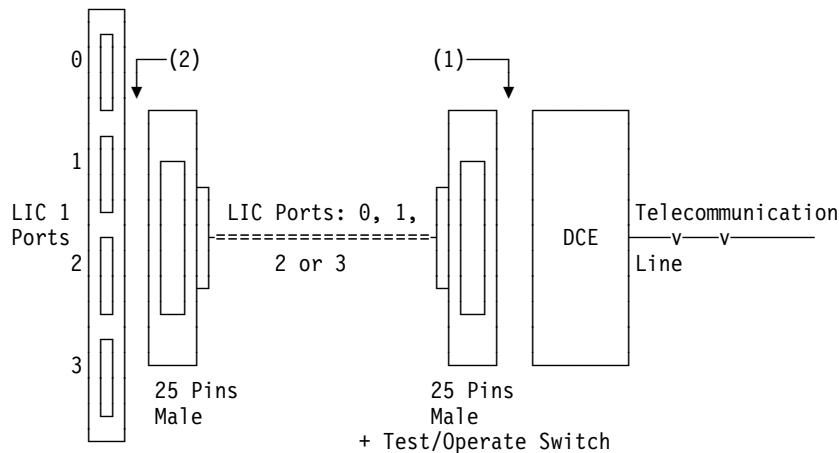

Interchange Circuits

To V.24 DCE (Japan Only)

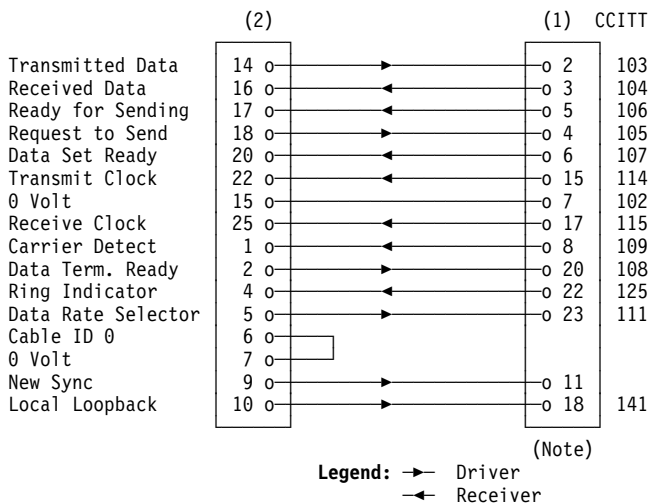

To X.21 Bis DCE (Japan Only)

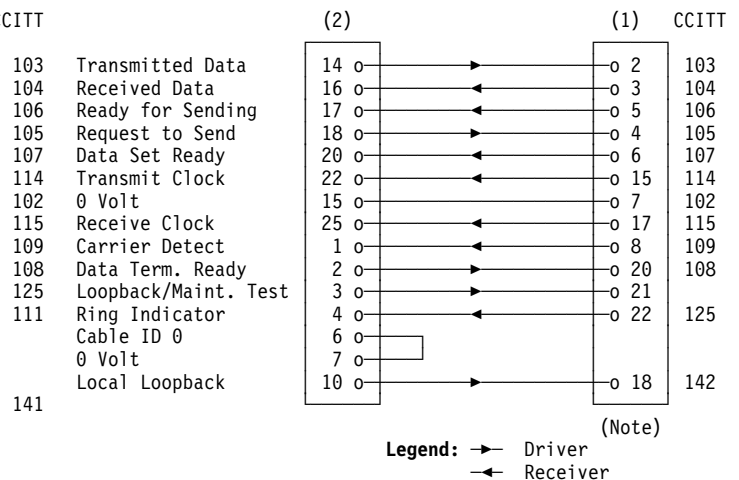

Note: This connector is equipped with a test/operate switch (see page 2-5).

Interface Cables

To V.24 DCE (Japan Only)

Cable Type and Length m (ft)	Feature Code	Cable Group	BM Number	Cable PN
13.5 m (45) or less	4911 (LIC1)	1621	6398662	6398662
More than 13.5 m (45) and up to 100 m (330)		N/A	6398782	6398782

To X.21 Bis DCE (Japan Only)



Cable Type and Length m (ft)	Feature Code	Cable Group	BM Number	Cable PN
13.5 m (45) or less	4911 (LIC1)	8153	61F4505	61F4505
More than 13.5 m (45) and up to 100 m (330)		N/A	61F4507	61F4507

Test/Operate Switch

Wiring Diagram

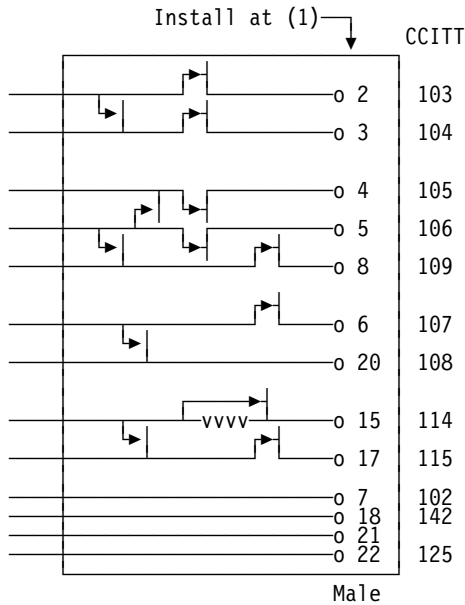
The diagram below shows the test/operate switch in the 'operate' position.



Legend:
 -vvvv- 1.6 kΩ Resistor
 Contact normally closed
 Contact normally open

Test Logical Function

The diagram below shows the test function with the switch in the 'test' position.

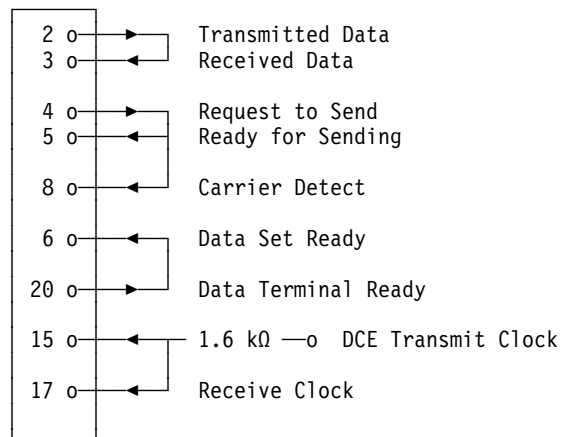

Wrapping

At Cartridge Connector

Install wrap plug PN 65X8927 in (2), ports 0, 1, 2, or 3.
See "TSS Wrap Tools" on page 2-29 for pin-to-pin assignment.

Voltage Levels

See "6.5 Volts" on page 2-32.

LIC Type 1 Auto-Call Unit Interface

Interface	CCITT V.25 (EIA RS 366)
Number of lines	Up to four

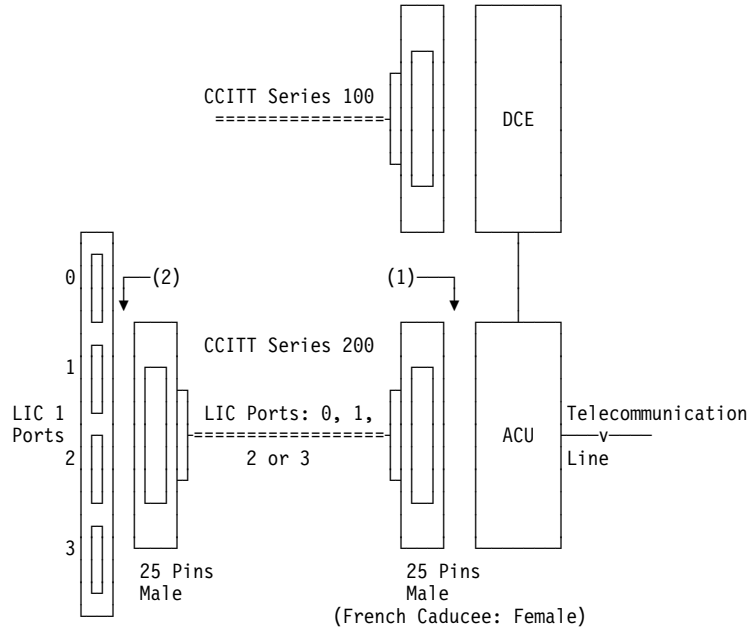

Interchange Circuits

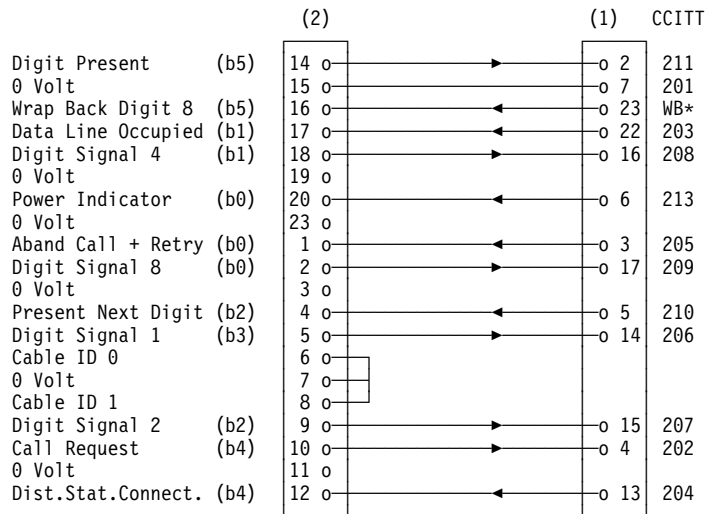

Legend: → Driver
 ← Receiver
 * Japan only (for maintenance purposes)

Interface Cables

To V.25 DCE Autocall Unit (Except U.K., France, Japan)

Cable Type and Length m (ft)	Feature Code	Cable Group	BM Number	Cable PN
Fixed length: 13.5 m (45)	4911 (LIC1)	1616	N/A	6398668
13.5 m (45) or less		1610	N/A	6398668
More than 13.5 m (45) and up to 35 m (115.5)		N/A	6398788	6398788

To V.25 DCE Autocall Unit U.K. (Adapter PN 674570 Included)

Cable Type and Length m (ft)	Feature Code	Cable Group	BM Number	Cable PN
13.5 m (45) or less	4911 (LIC1)	1635	6398670	6398670
More than 13.5 m (45) and up to 35 m (115.5)		N/A	6398787	6398787

* Cable group 1618 includes the cable and the adapter

To V.25 DCE France (Caducee)

Cable Type and Length m (ft)	Feature Code	Cable Group	BM Number	Cable PN
13.5 m (45) or less	4911 (LIC1)	1622	6398667	6398667
More than 13.5 m (45) and up to 35 m (115.5)		N/A	6398783	6398783

To V.25 DCE Japan NTT

Cable Type and Length m (ft)	Feature Code	Cable Group	BM Number	Cable PN
13.5 m (45) or less	4911 (LIC1)	1634	6398664	6398664
More than 13.5 m (45) and up to 35 m (115.5)		N/A	6398786	6398786

Adapter Cable

U.K. (PN 674570)

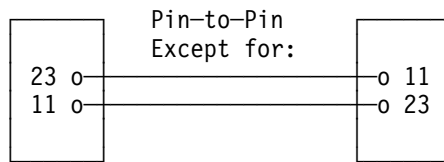

Wrapping

At Cartridge Connector

Install wrap plug PN 65X8927 in (2), ports 0, 1, 2, or 3.

See "TSS Wrap Tools" on page 2-29 for pin-to-pin assignment.

Voltage Levels

See "6.5 Volts" on page 2-32.

LIC Type 1 Direct Attachment Interface

Interface	CCITT V.24 (EIA 232C) CCITT X.21 Bis
Transmission speed	Up to 19 200 bps
Number of lines	Up to four
Transfer mode	Half-duplex or duplex
Protocols	Start-stop, BSC, SDLC
DTE clocking	Up to 19 200 bps

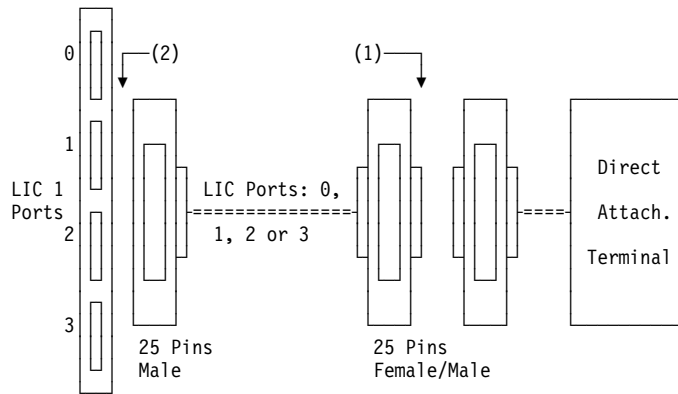

Interchange Circuits

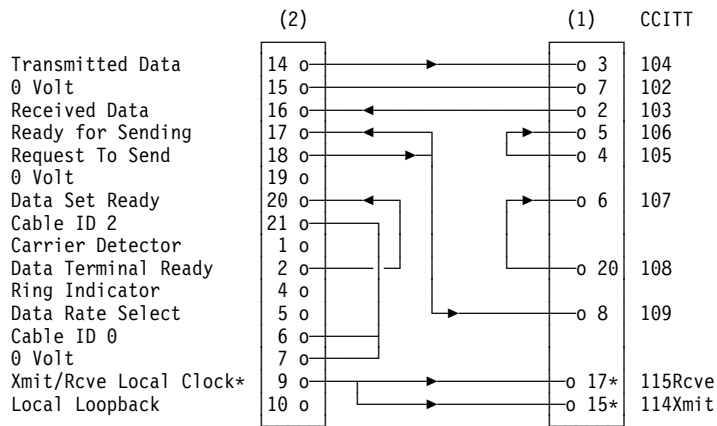

Legend: → Driver
 ← Receiver
 * 3745 provides Xmit (transmit) and Rcve (receive) clocks to the terminal.

Interface Cables

To V.24 Direct Attachment Synchronous

This cable has a female connector at the terminal side.

Cable Type and Length m (ft)	Feature Code	Cable Group	BM Number	Cable PN
Fixed length: 13.5 m (45) (See the note below)	4911 (LIC1)	1611	7837395	7837395
13.5 m (45) or less		1627	7837395	7837395
More than 13.5 m (45) and up to 122 m (400)		N/A	7837396	7837396

Note: Fixed length is not available in European, Middle Eastern, and African countries.

To V.24 Direct Attachment Asynchronous (Teletype)

This cable has a male connector at the terminal side.

Cable Type and Length m (ft)	Feature Code	Cable Group	BM Number	Cable PN
Fixed length: 13.5 m (45) (See the note below)	4911 (LIC1)	1607	7837397	7837397
13.5 m (45) or less		1612	7837397	7837397
More than 13.5 m (45) and up to 122 m (400)		N/A	7837398	7837398

Note: Fixed length is not available in European, Middle Eastern, and African countries.

Wrapping

At Cartridge Connector

Install wrap plug PN 65X8927 in (2), ports 0, 1, 2, or 3.

See "TSS Wrap Tools" on page 2-29 for pin-to-pin assignment.

Voltage Levels

See "6.5 Volts" on page 2-32.

LIC Type 3 DCE Interface

Interface	CCITT V.35
Transmission speed	Up to 256 000 bps
Number of lines	One
Transfer mode	Half-duplex or duplex
Protocols	BSC and SDLC
DTE clocking	Not allowed

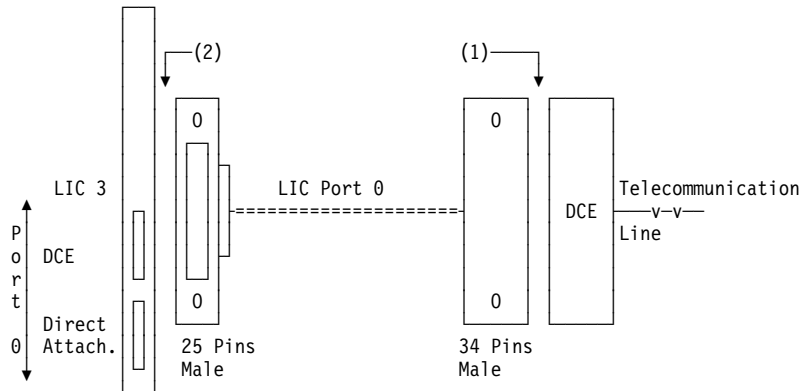

Notes:

1. Upper socket is for DCE attachment.
2. Lower socket is for direct attachment to a terminal.

Interchange Circuits

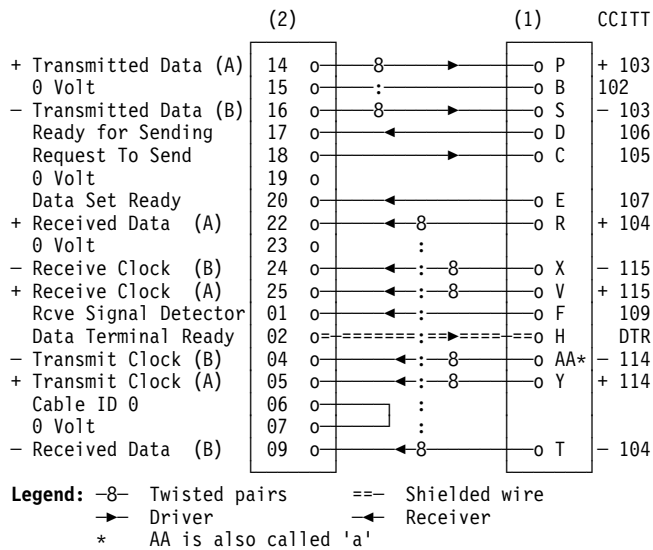

Interface Cables

To V.35 DCE Except France

Cable Type and Length m (ft)	Feature Code	Cable Group	BM Number	Cable PN
Fixed length: 13.5 m (45)	4931 (LIC1)	1613	58X9485	58X9485
13.5 m (45) or less		1618	58X9485	58X9485
More than 15 m (49.5) and up to 100 m (328)		N/A	6398665	6398665

To V.35 DCE France Only (Adapter PN 1749352 Included)

Cable Type and Length m (ft)	Feature Code	Cable Group	BM Number	Cable PN
Fixed length: 13.5 m (45)	4931 (LIC1)	1619	58X9198	65X9522
13.5 m (45) or less		1619	6398671	6398671
More than 15 m (49.5) and up to 100 m (328)		N/A	6398789	6398789

Wrapping

At Cartridge Connector

Install wrap cable PN 65X8928 in (2), between port 0 and the DCE socket. See "TSS Wrap Tools" on page 2-29 for pin-to-pin assignment.

Note: For a full test, run the test with the wrap cable installed, then reverse the cable ends (between port 0 and DCE socket) and repeat the test.

Voltage Levels

See "0.55 Volt (V.35 Balanced Circuits)" on page 2-32.

LIC Type 3 Direct Attachment Interface

Interface	CCITT V.35
Transmission speed	Up to 245 760 bps (Up to 256 000 bps through RPQ)
Number of lines	One
Transfer mode	Half-duplex or duplex
Protocols	BSC and SDLC
DTE clocking	Up to 256 000 bps

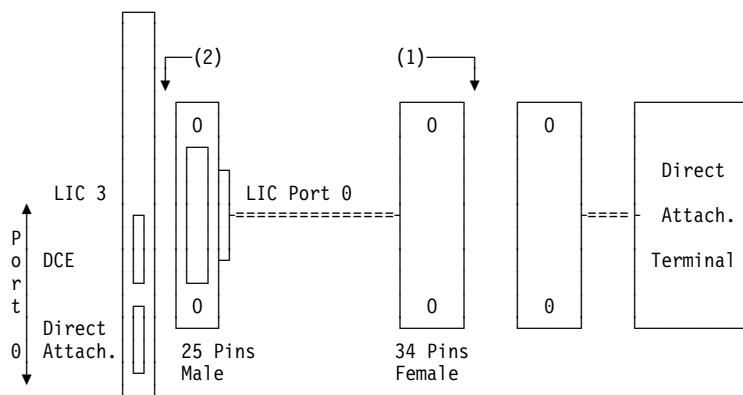

Notes:

1. Upper socket is for DCE attachment.
2. Lower socket is for direct attachment to terminal.

Interchange Circuits

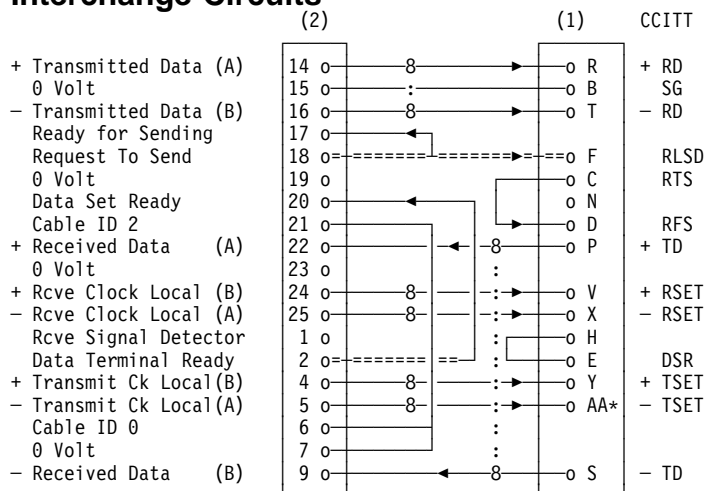

- Legend:**
- 8- Twisted pair
 - ==== Shielded wire
 - Driver
 - ← Receiver
 - * AA is also called 'a'

Interface Cables

To V.35 Direct Attachment (Except France)

Cable Type and Length m (ft)	Feature Code	Cable Group	BM Number	Cable PN
Fixed length: 13.5 m (45)	4931 (LIC1)	1605	58X9484	58X9484
13.5 m (45) or less		1623	58X9484	58X9484
More than 13.5 m (45) and up to 122 m (400)		N/A	6398657	6398657

To V.35 Direct Attachment (France Only)

Cable Type and Length m (ft)	Feature Code	Cable Group	BM Number	Cable PN
13.5 m (45) or less	4931 (LIC1)	1623F	65X9900	65X9900
More than 13.5 m (45) and up to 122 m (400)		N/A	65X9900	65X9900

Wrapping

At Cartridge Connector

Install wrap cable PN 65X8928 in (2), between port 0 and the DCE socket. See "TSS Wrap Tools" on page 2-29 for pin-to-pin assignment.

Note: For a full test, run the test with the wrap cable installed, then reverse the cable ends (between port 0 and DCE socket) and repeat the test.

Voltage Levels

See "0.55 Volt (V.35 Balanced Circuits)" on page 2-32.

LIC Type 4A DCE Interface

Interface	CCITT X.21
Transmission speed	Up to 9600 bps
Number of lines	Four
Transfer mode	Half-duplex or duplex
Protocols	SDLC
DTE clocking	Not allowed

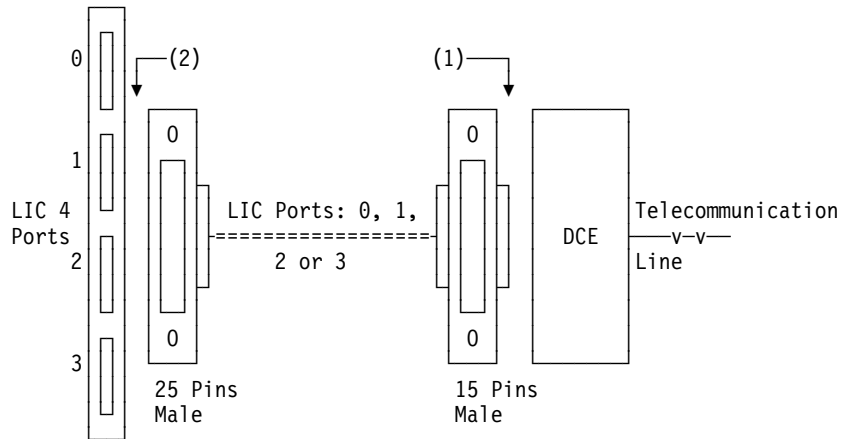

Interchange Circuits

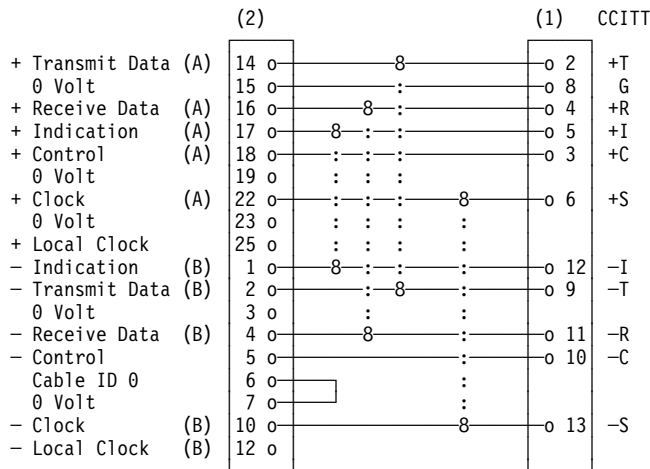

Legend: -8- Twisted pair
 → Driver
 ← Receiver

Interface Cables To X.21 DCE

Cable Type and Length m (ft)	Feature Code	Cable Group	BM Number	Cable PN
Fixed length: 13.5 m (45)	4941 (LIC1)	1606	03F4913 (EMEA)	58X9487
13.5 m (45) or less		1624	58X9487	58X9487
More than 13.5 m (45) and up to 122 m (400)		N/A	6398658	6398658

Wrapping At Cartridge Connector

Install wrap plug PN 65X8927 in (2), ports 0, 1, 2, or 3.
See "TSS Wrap Tools" on page 2-29 for pin-to-pin assignment.

Voltage Levels

See "3 Volts" on page 2-32.

LIC Type 4A Direct Attachment Interface

Interface	CCITT X.21
Transmission speed	Up to 9600 bps
Number of lines	Four
Transfer mode	Half-duplex or duplex
Protocols	SDLC
DTE clocking	Up to 9600 bps

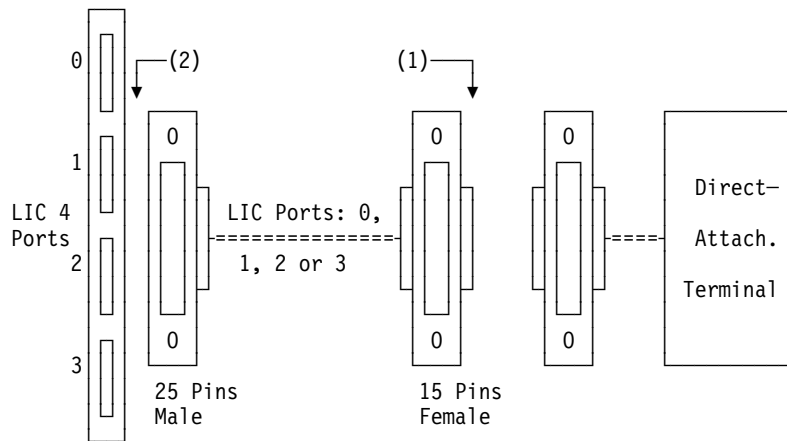

Interchange Circuits

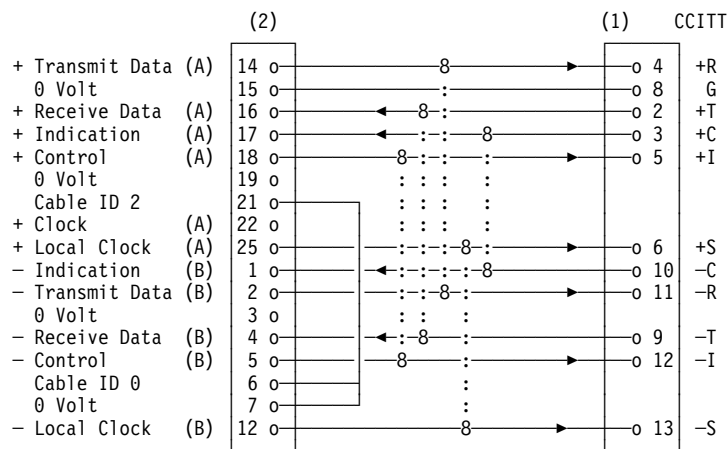

Legend: -8- Twisted pair
 → Driver
 ← Receiver

Interface Cables

To X.21 Direct Attachment

Cable Type and Length m (ft)	Feature Code	Cable Group	BM Number	Cable PN
Fixed length: 30 m (99)	4941 (LIC4A) (No EMEA)	1608	58X9486	58X9486
30 m (99) or less		1625	58X9486	58X9486
More than 30 m (99) and up to 122 m (400)		N/A	6398660	6398660

Wrapping

At Cartridge Connector

Install wrap plug PN 65X8927 in (2), port 0.
See "TSS Wrap Tools" on page 2-29 for pin-to-pin assignment.

Voltage Levels

See "3 Volts" on page 2-32.

LIC Type 4B DCE Interface

Interface	CCITT X.21
Transmission speed	Up to 256 000 bps
Number of lines	One
Transfer mode	Half-duplex or duplex
Protocols	SDLC
DTE clocking	Not allowed

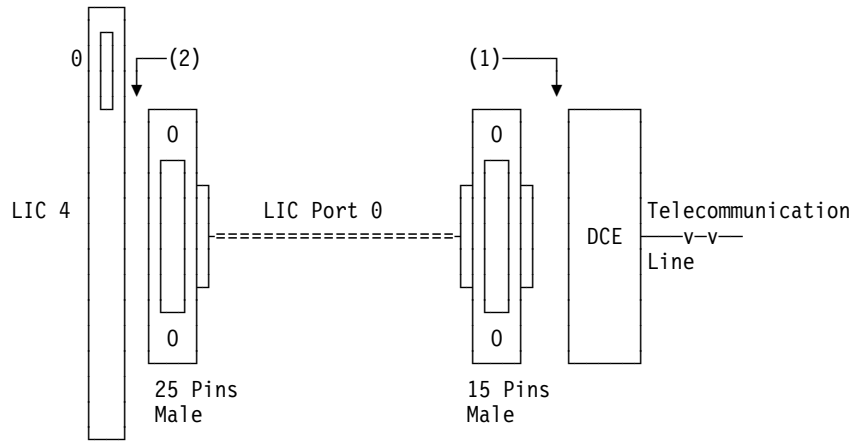

Interchange Circuits

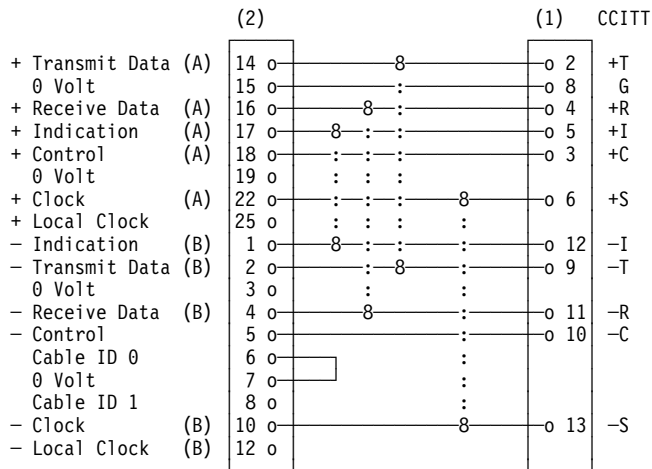

Legend: -8- Twisted pair
 → Driver
 ← Receiver

Interface Cables To X.21 DCE

Cable Type and Length m (ft)	Feature Code	Cable Group	BM Number	Cable PN
Fixed length: 13.5 m (45)	4942 (LIC4B)	1606	03F4914 (EMEA)	58X9487
13.5 m (45) or less		1624	58X9487	58X9487
More than 13.5 m (45) and up to 122 m (400)		N/A	6398658	6398658

Wrapping At Cartridge Connector

Install wrap plug PN 65X8927 in (2), port 0.
See "TSS Wrap Tools" on page 2-29 for pin-to-pin assignment.

Voltage Levels

See "3 Volts" on page 2-32.

LIC Type 4B DCE Interface (France Transfix Only)

Interface	CCITT X.21
Transmission speed	Up to 256 000 bps
Number of lines	One
Transfer mode	Half-duplex or duplex
Protocols	SDLC
DTE clocking	Not allowed

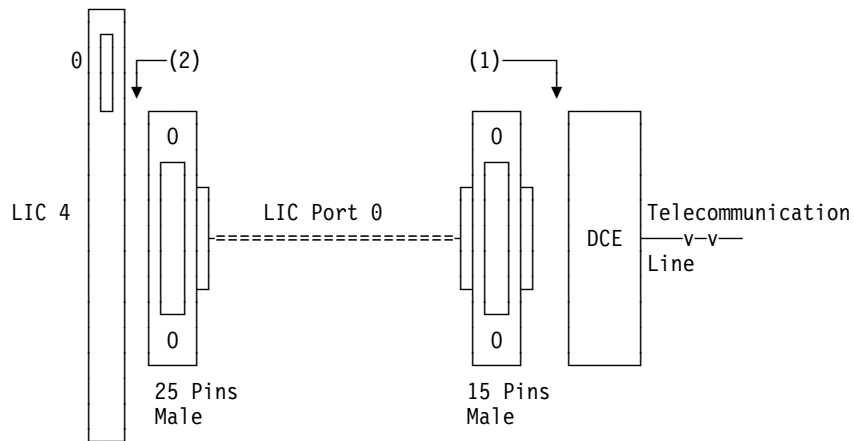

Interchange Circuits

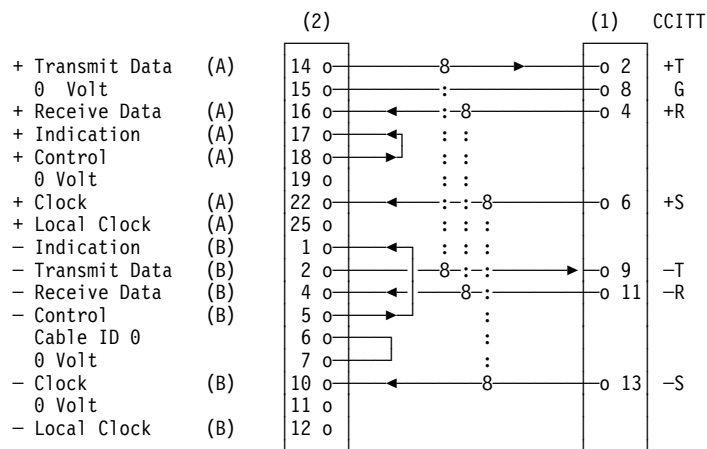

Legend: -8- Twisted pair
 → Driver
 ← Receiver

Interface Cables

To X.21 DCE Transfix France

Cable Type and Length m (ft)	Feature Code	Cable Group	BM Number	Cable PN
Fixed length: 13.5 m (45)	4942 (LIC4B)	1609	03F4915 (EMEA)	58X9488
13.5 m (45) or less		1609	58X9488	58X9488
More than 13.5 m (45) and up to 122 m (400)		N/A	6398661	6398661

Wrapping

At Cartridge Connector

Install wrap plug PN 65X8927 in (2), port 0.
See "TSS Wrap Tools" on page 2-29 for pin-to-pin assignment.

Voltage Levels

See "3 Volts" on page 2-32.

LIC Type 4B Direct Attachment Interface

Interface	CCITT X.21
Transmission speed	Up to 256 000 bps
Number of lines	One
Transfer mode	Half-duplex or duplex
Protocols	SDLC
DTE clocking	Up to 256 000 bps

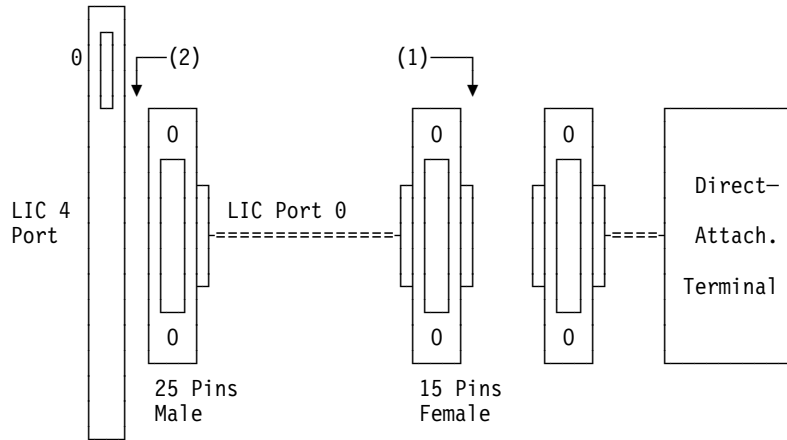

Interchange Circuits

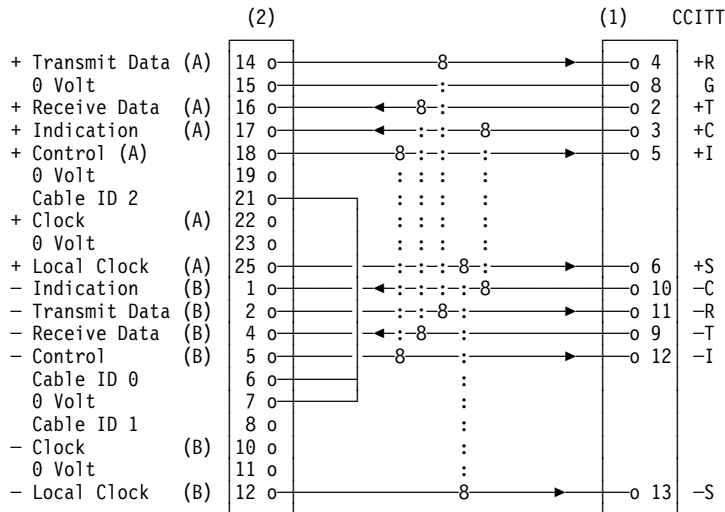

Legend: -8- Twisted pair
 → Driver
 ← Receiver

Interface Cables

To X.21 Direct Attachment

Cable Type and Length m (ft)	Feature Code	Cable Group	BM Number	Cable PN
Fixed length: 13.5 m (45)	4942 (LIC4B) (No EMEA)	1608	58X9486	58X9486
30 m (99) or less		1625	58X9486	58X9486
More than 30 m (99) and up to 122 m (400)		N/A	6398660	6398660

Wrapping

At Cartridge Connector

Install wrap plug PN 65X8927 in (2), port 0.
See "TSS Wrap Tools" on page 2-29 for pin-to-pin assignment.

Voltage Levels

See "3 Volts" on page 2-32.

LIC5 and LIC6 Interfaces and Cables

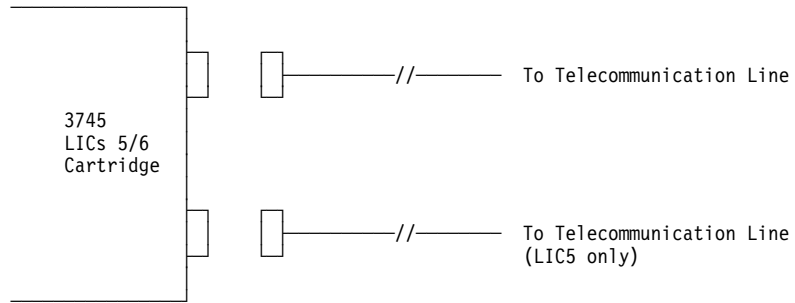

The 3745 provides line cables to the customer's telecommunication socket (see *Power Supply and Telecommunication Connections for IBM Modems, GA33-0054*).

LIC Type 5 Line Interface

Transmission speed	4800 or 9600 or 14 400 bps
Number of lines	Two
Transfer mode	Half-duplex or duplex
Protocols	BSC, SDLC

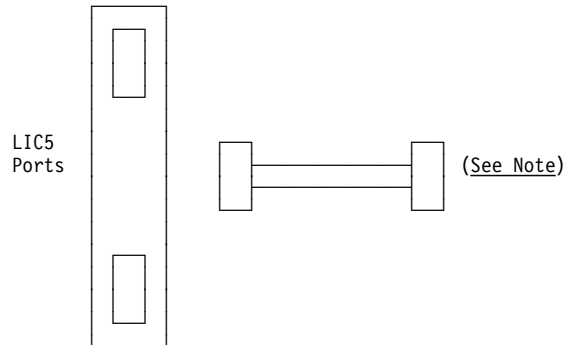

Note: See *Power Supply and Telecommunication Connections for IBM Modems, GA33-0054*.

Interchange Circuits

Lead Color	Pin Assignments (LIC5 Side)	Pin Assignments (Line Side)	Signal Name
Blue	1	(See Note above)	Receive (Rec) 1
Orange	2		Receive (Rec) 2
Yellow	7		Transmit (Tsm) 1
Black	8		Transmit (Tsm) 2

Interface Cables

Refer to *Power Supply and Telephone Connections for IBM Modems, GA33-0054*.

Wrapping

At Cartridge Connector: Install wrap plug PN 11F4815. See "TSS Wrap Tools" on page 2-29 for pin-to-pin assignment.

At Cable End: Install national wrap plug at cable end (see MIP for PNs). All wrap plugs wrap Receive 1 to Transmit 1 and Receive 2 to Transmit 2.

LIC Type 6 Line Interface

Transmission speed	Up to 56 000 bps
Number of lines	One
Transfer mode	Half-duplex or duplex
Protocols	BSC, SDLC

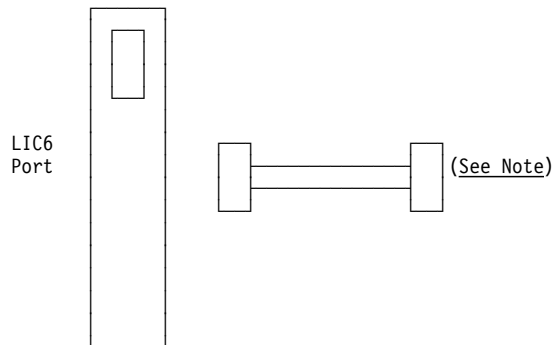

Note: See *Power Supply and Telecommunication Connections for IBM Modems, GA33-0054*.

Interchange Circuits

Lead Color	Pin Assignments (LIC6 Side)	Pin Assignments (Line Side)	Signal Name
Blue	1	(See Note above)	Receive (Rec) 1
Orange	2		Receive (Rec) 2
Yellow	7		Transmit (Tsm) 1
Black	8		Transmit (Tsm) 2

Interface Cables

Refer to *Power Supply and Telephone Connections for IBM Modems, GA33-0054*.

Wrapping

At Cartridge Connector: Install wrap plug PN 11F4815. See "TSS Wrap Tools" on page 2-29 for pin-to-pin assignment.

At Cable End: Install national wrap plug at cable end (see MIP for PNs). All wrap plugs wrap Receive 1 to Transmit 1 and Receive 2 to Transmit 2.

TSS Wrap Tools

Wrap Plug PN 65X8927

For LIC 1 and LIC 4

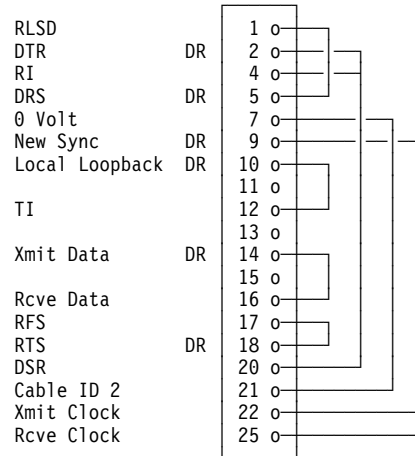
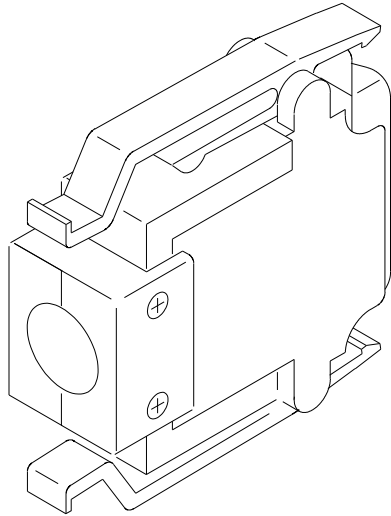

Wrap Tool PN 65X8928

For LIC 3

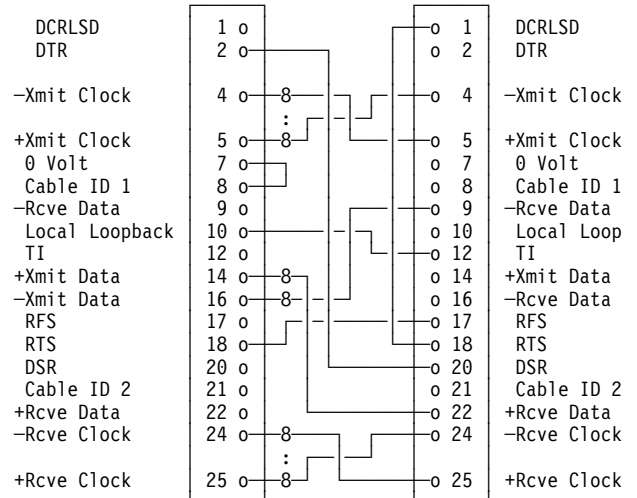
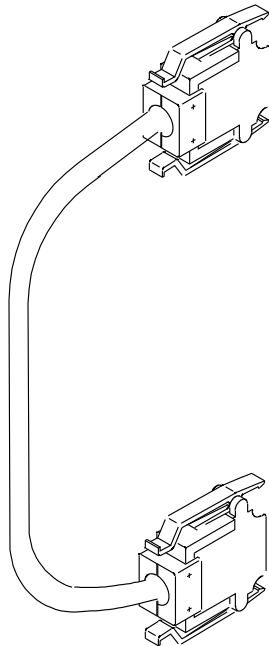

This wrap cable is plugged between the upper socket and the lower socket of a LIC 3 (plugging is interchangeable).

Wrap Plug PN 11F4815

For LIC 5 and LIC 6

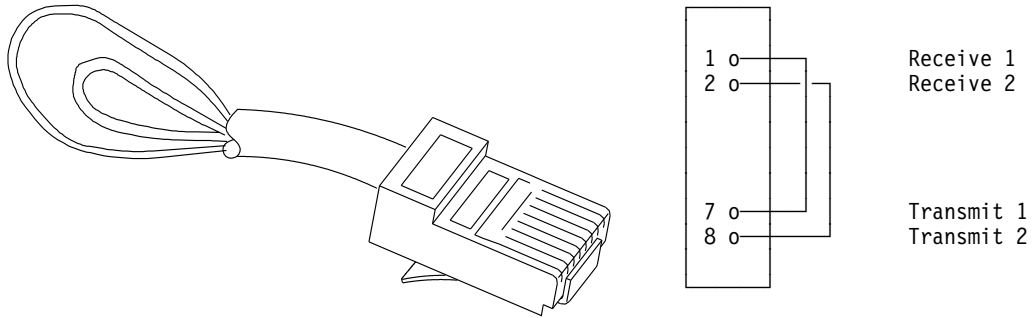

PKD Interface

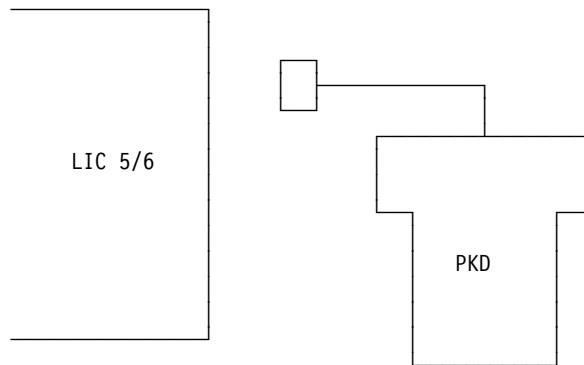

Connector And Pin Assignment

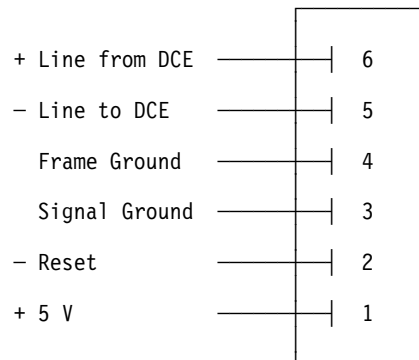

PT2/3 Interface

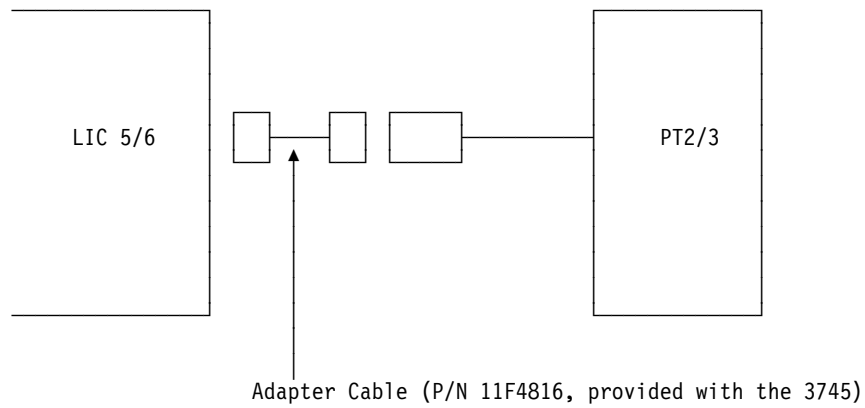

Note: When using the PT2/3 device, the SLT/VTL switch must be set to ON.

Pin Assignments on Adapter Cable

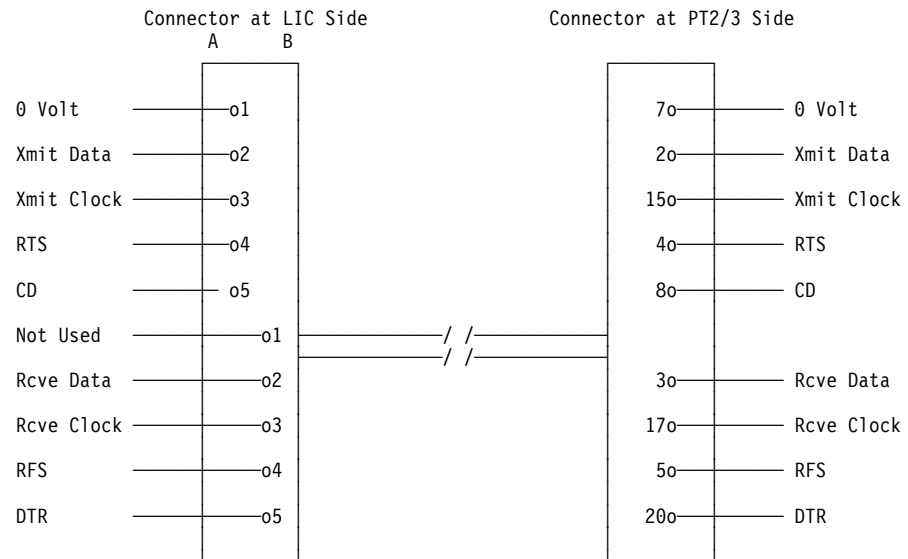

Driver/Receiver Typical Voltage Operating Ranges

3 Volts

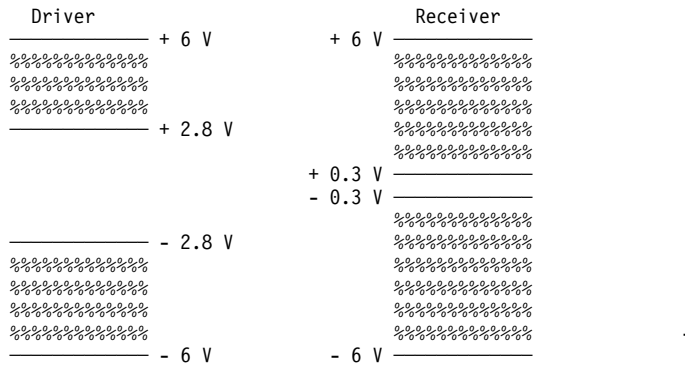

6.5 Volts

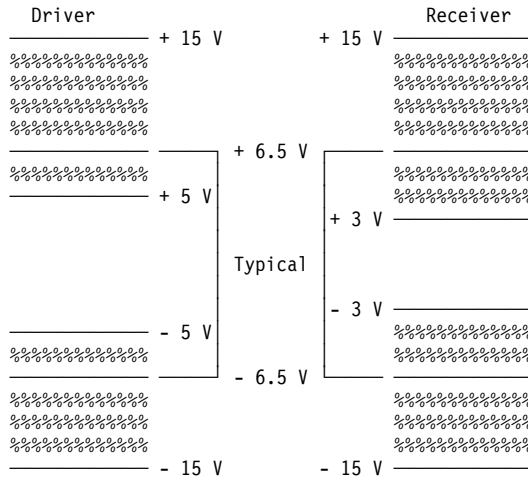

0.55 Volt (V.35 Balanced Circuits)

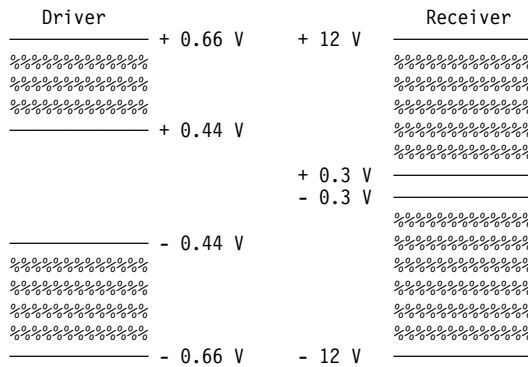

Between wires A and B of given signal for:

- ± Transmitted data
- ± Received data
- ± Receiver signal element timing
- ± Transmitter signal element timing

Note: For other V.35 unbalanced circuits, see 6.5 Volts above.

Chapter 3. HPTSS Interface Cables

DTE/DCE Cable Connectors

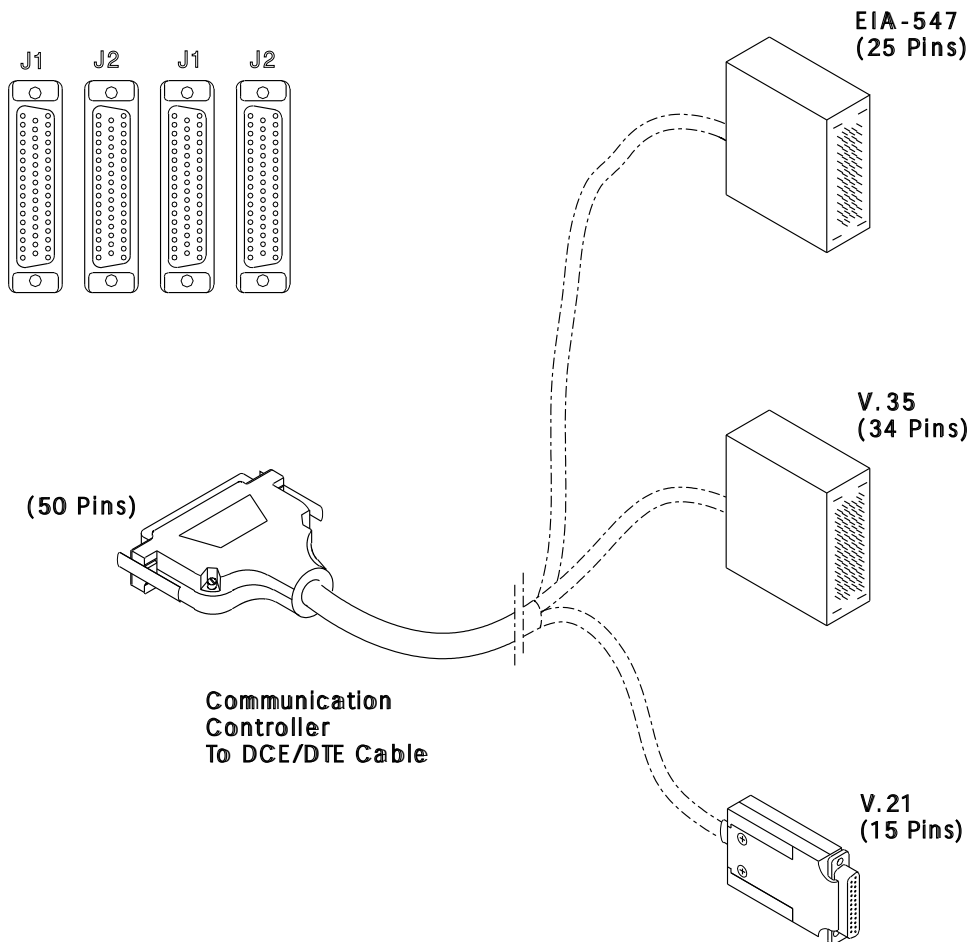

For cable ordering, see the HPTSS cable descriptions in the following pages.

Feature Code: The HPTSS cable feature code is:

- **4740** for the 3745 Models 210, 310, 410, 610, and X1A.
- **4741** for the 3745 Models 130, 150, 170, and 17A.
- **5212** for the 3746-900.

V.35 Interface to DCE

Cable Type	Length, m (ft)	Cable Group	Cable PN
Standard Fixed	10 m (33)	5831	58X9344
Variable	Less than 10 m (33)	5830	58X9344
Variable	Up to 35 m (115) (See note below)	NA	58X9344

Feature Code: 4740 is for 3745 Models 210, 310, 410, 610, and X1A
 4741 is for 3745 Models 130, 150, 160, 170, and 17A
 5212 is for 3746-900

Note:

The HPTSS/LIC12 cable length is limited to 10 m (33 ft), if circuit 113 is not supported by the DCE. The 35 m (115 ft) maximum cable length is authorized if circuit 113 is supported by the DCE. Circuit 113 (Transmit Clock 2) is circuit 114 (Transmit Clock 1) from the DCE looped back to the DCE. Circuit 113 and LIC12/HSS Transmit Data are synchronous. The option to support circuit 113 may or may not be available on the manufacturer's DCE. Verify that this support exists by reading the documentation on your DCE, and select the options that correspond to your cable length.

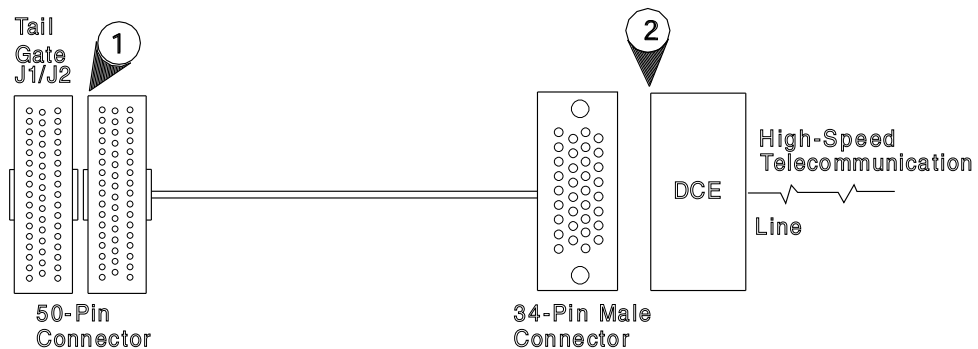

Interchange Circuits

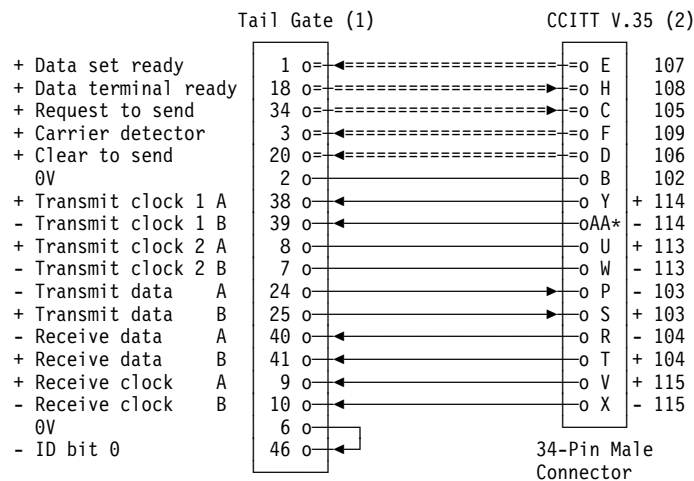

Legend: == Shielded wires
 * AA is also named 'a'

Voltage levels: Refer to "Voltage Interface Measurements" on page 3-9 for information.

V.35 Direct Attach Cable

Cable Type	Length, m (ft)	Cable Group	Cable PN
Standard Fixed	10 m (33)	5837	58X9347
Variable	Less than 10 m (33)	5836	58X9347
Variable	Up to 100 m (330)	NA	58X9347

Feature Code: 4740 is for 3745 Models 210, 310, 410, 610, and X1A
 4741 is for 3745 Models 130, 150, 160, 170, and 17A
 5212 is for 3746-900

Cable to DTE

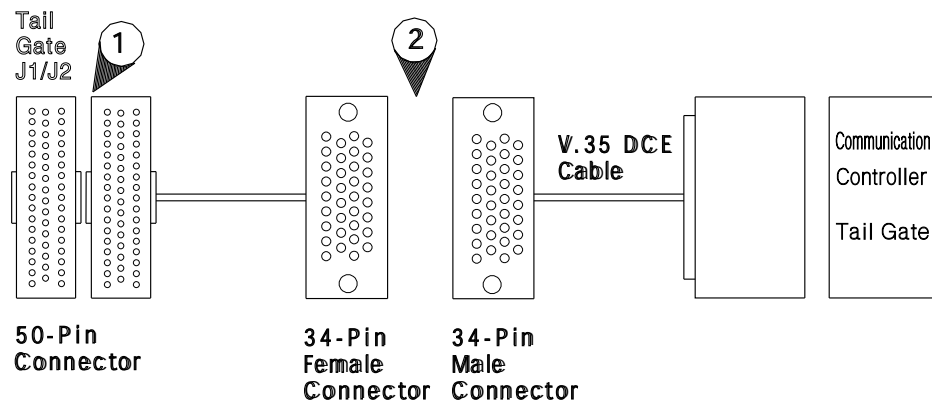

Interchange Circuits

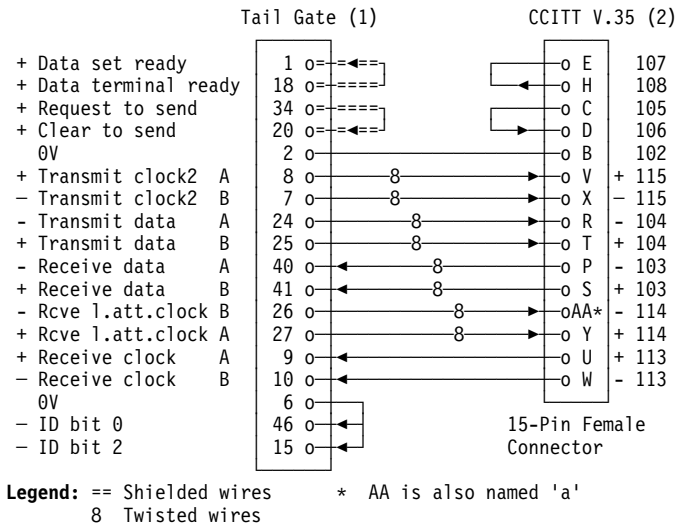

Voltage Levels: Refer to "Voltage Interface Measurements" on page 3-9 for information.

X.21 Interface to DCE (Including Transfix France at 1.920Mbps)

Cable Type	Length, m (ft)	Cable Group	Cable PN
Standard Fixed	10 m (33)	5833	58X9345
Variable	Less than 10 m (33)	5832	58X9345

Feature Code: 4740 is for 3745 Models 210, 310, 410, 610, and X1A
 4741 is for 3745 Models 130, 150, 160, 170, and 17A
 5212 is for 3746-900

Cable to DCE

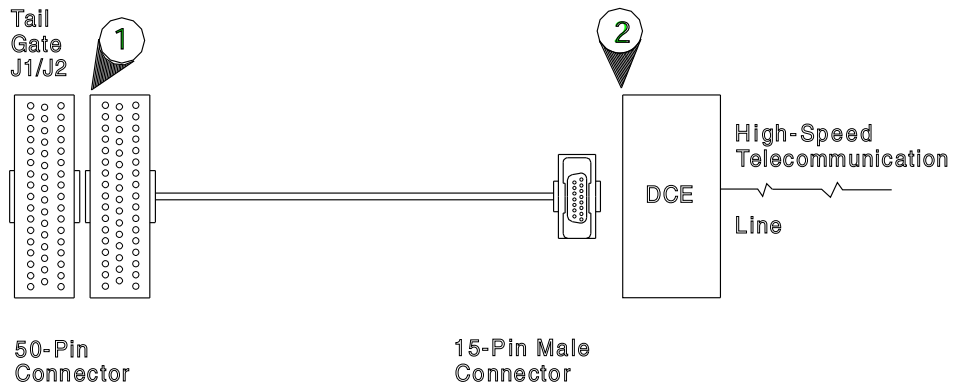

Interchange Circuits

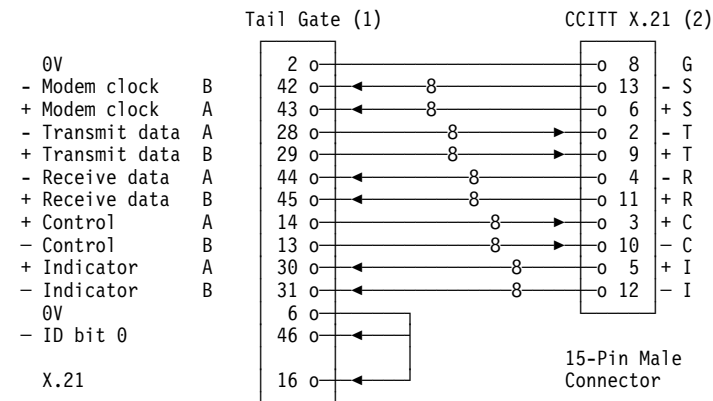

X.21 Interface to DCE (Transfix France, Except 1.920 Mbps)

Cable Type	Length, m (ft)	Cable Group	Cable PN
Standard Fixed	10 m (33)	5835	58X9346
Variable	Less than 10 m (33)	5834	58X9346

Feature Code: 4740 is for 3745 Models 210, 310, 410, 610, and X1A
 4741 is for 3745 Models 130, 150, 160, 170, and 17A
 5212 is for 3746-900

Cable to DCE

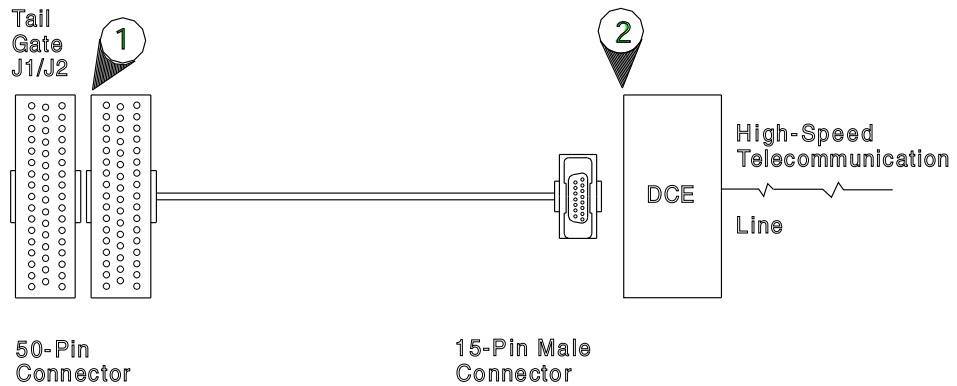

Interchange Circuits

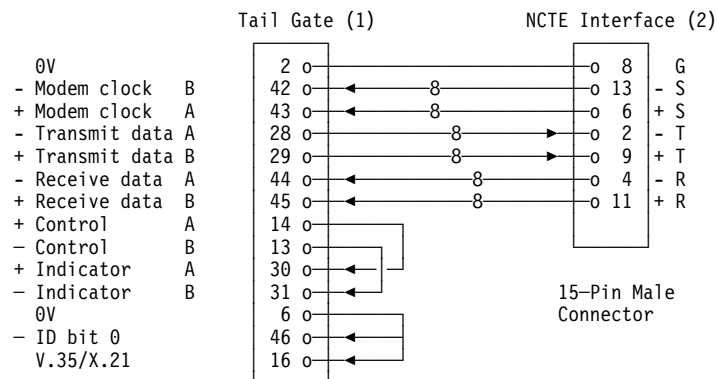

Legend: 8 Twisted wires

Voltage levels: Refer to "Voltage Interface Measurements" on page 3-9 for information.

X.21 Direct Attach Cable

Cable Type	Length, m (ft)	Cable Group	Cable PN
Standard Fixed	10 m (33)	5839	58X9348
Variable	Less than 10 m (33)	5838	58X9348

Feature Code: 4740 is for 3745 Models 210, 310, 410, 610, and X1A
 4741 is for 3745 Models 130, 150, 160, 170, and 17A
 5212 is for 3746-900

Cable to DTE

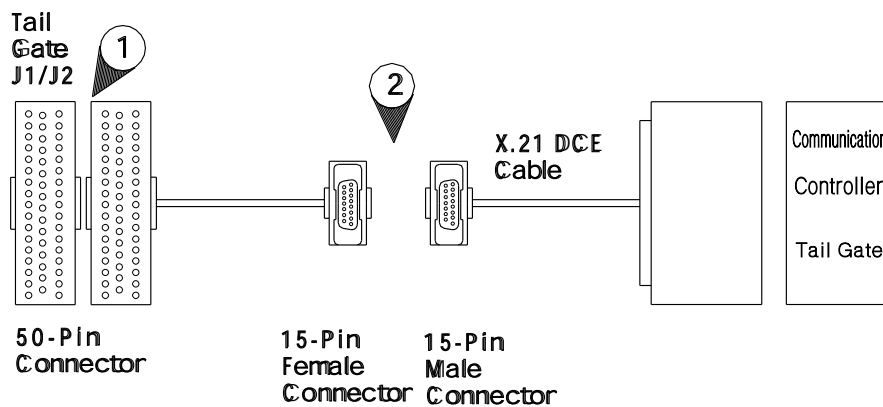

Interchange Circuits

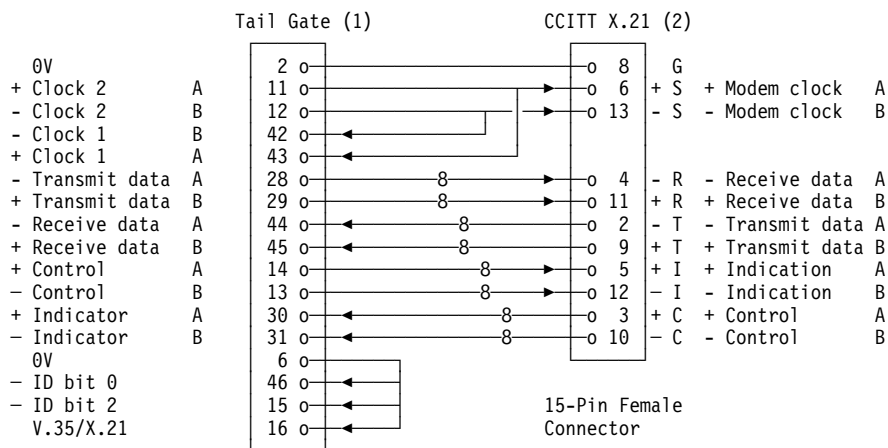

Voltage levels: Refer to "Voltage Interface Measurements" on page 3-9 for information.

EIA-547 Interface to DCE

Cable Type	Length, m (ft)	Cable Group	Cable PN
Standard Fixed	10 m (33)	5844	11F4837
Variable	Less than 10 m (33)	5842	11F4837
Variable	Up to 35 m (115)	NA	11F4837

Feature Code: 4740 is for 3745 Models 210, 310, 410, 610, and X1A
 4741 is for 3745 Models 130, 150, 160, 170, and 17A
 5212 is for 3746-900

Cable to DCE

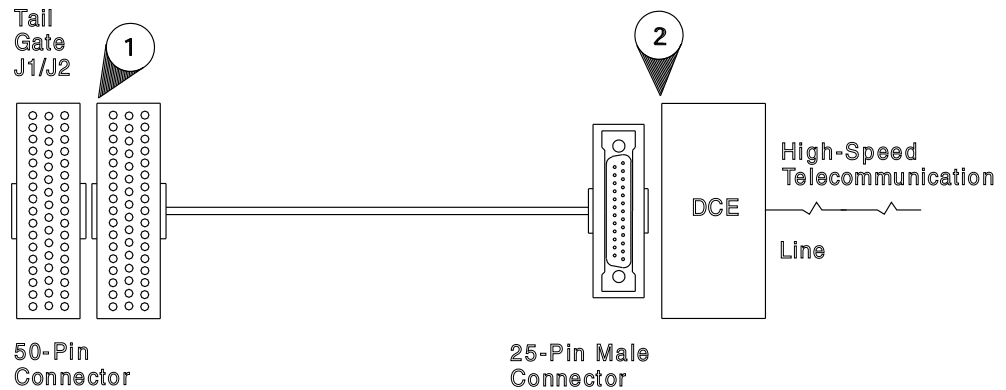

Interchange Circuits

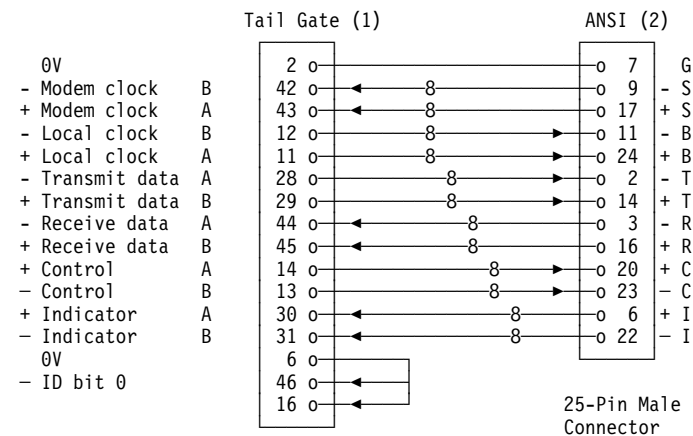

Legend: 8 Twisted wires

Voltage levels: Refer to "Voltage Interface Measurements" on page 3-9 for information.

EIA-547 Direct Attach Cable

Cable Type	Length, m (ft)	Cable Group	Cable PN
Standard Fixed	10 m (33)	5845	11F4838
Variable	Less than 10 m (33)	5843	11F4838
Variable	Up to 100 m (328)	NA	11F4838

Feature Code: 4740 is for 3745 Models 210, 310, 410, 610, and X1A
 4741 is for 3745 Models 130, 150, 160, 170, and 17A
 5212 is for 3746-900

Cable to DTE

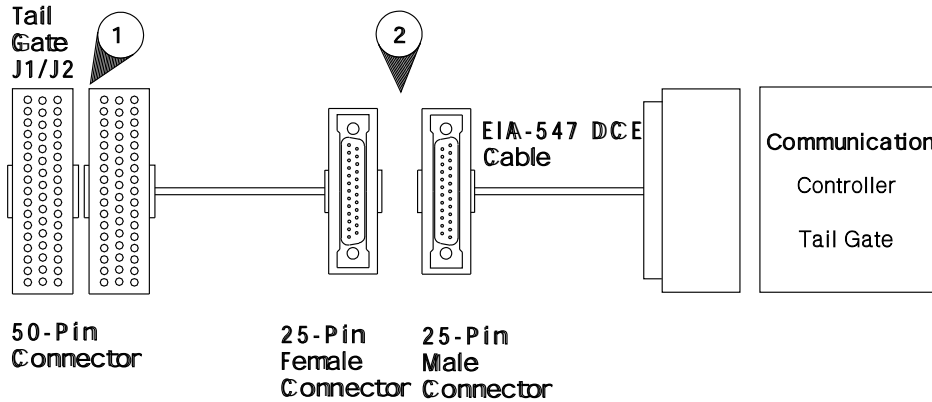

Interchange Circuits

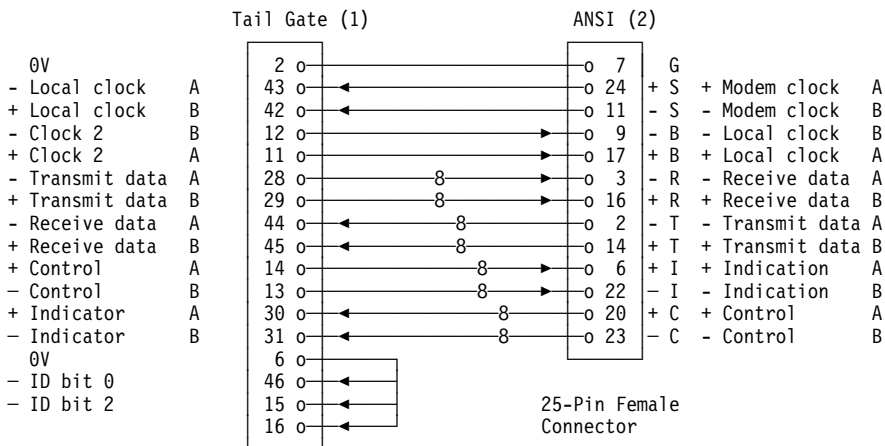

Legend: 8 Twisted wires

Voltage levels: Refer to "Voltage Interface Measurements" on page 3-9 for information.

Voltage Interface Measurements

V.35 Interface Signal Name	CCITT Circuit Number	Level	Voltage
CTS	105	ON OFF	> +3 V < -3 V
DTR	108.2	ON OFF	> +3 V < -3 V
TC	140	ON OFF	> +3 V < -3 V
Transmit Data	103	0 1	a>b 0.275 V a<b 0.275 V
Transmit Clock2	113	0 1	a>b 0.275 V a<b 0.275 V
Receive Local Attach	—	0 1	a>b 0.275 V a<b 0.275 V
X.21 Interface			
Transmit Data	T	0 1	a>b 0.275 V a<b 0.275 V
Control	C	0 1	a>b 0.275 V a<b 0.275 V

HPTSS Wrap Plugs

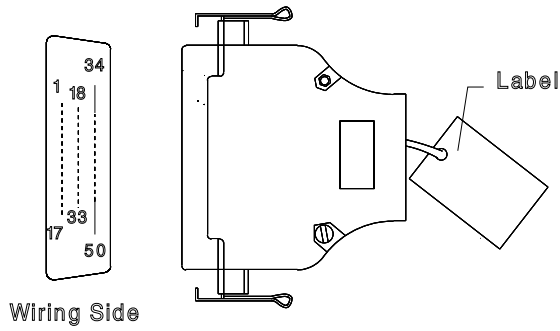

Wrap Plug V.35 PN 58X9349

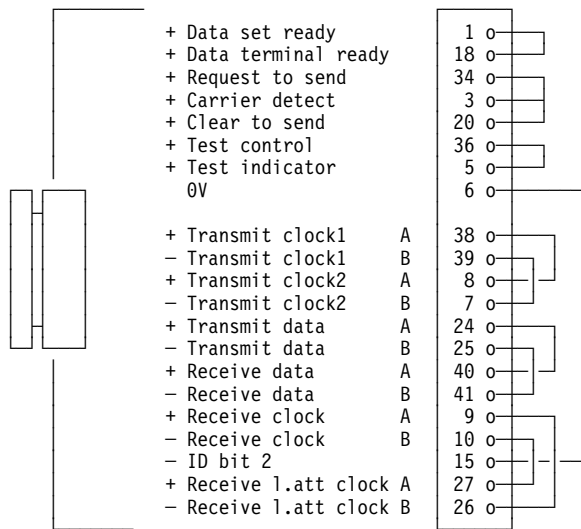

Wrap Plug X.21 PN 58X9354

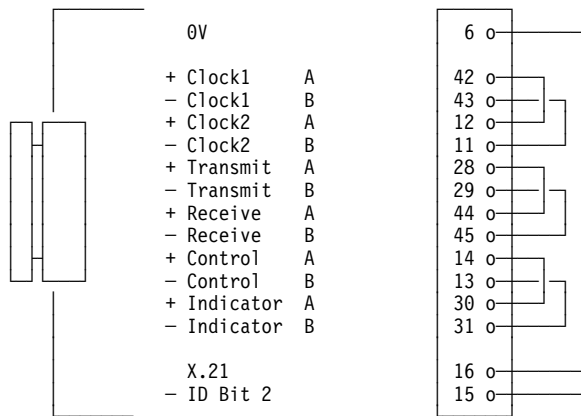

Chapter 4. TRSS Interface Cable

TIC Card to Tailgate Cable



To TIC Card

To Tailgate

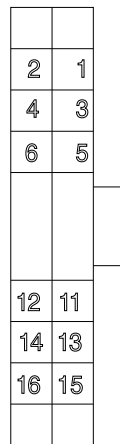

Pin Position
(Mating Side)

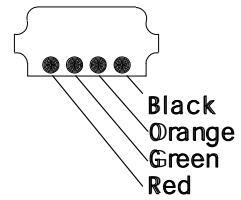

Interchange Circuits

Signal Name	Color	Pin Connector (Socket Side)
+ Ring out A	Black	Position 16
+ Ring out B	Orange	Position 15
+ Ring in A	Green	Position 1
+ Ring in B	Red	Position 2

Cable to Ring Wall Connector

The access to the ring interface is via the attachment cable.

Cable Type	Length, m (ft)	Cable Group	Cable PN	BM Number
Fixed (U.S.A.)	21.3 m (70)	1666	61X3229	61X3229
Fixed (EMEA)	9 m (30)	1666	8642552	03F4906
Variable	Up to 21.3 m (70)	1667	61X3229	61X3229
Variable	Up to 44.2 m (145)	NA	61X3229	61X3229

* **Feature Code:** 4760 is for 3745 Models 210, 310, 410, 610, and X1A
 4771 is for 3745 Models 130, 150, 160, 170, and 17A
 5212 is for 3746-900

Note: In the case where the ring is made of a twisted telephone pair, a 'Data Grade Media to Type 3 Media Filter' must be inserted between the end of the twisted telephone pair and the 3745 (see the following figure).

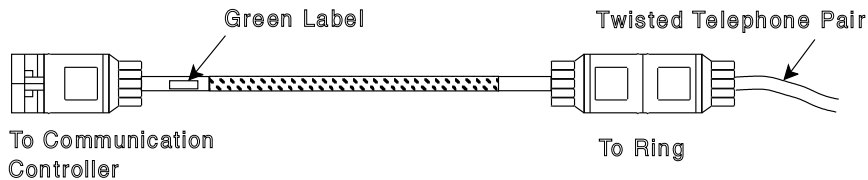

Voltage Levels (Ring Transmitter/Receiver)

Ring Receiver

Minimum input signal: 50 millivolts peak-to-peak

Ring Transmitter

Output signal: Between 3.0 and 4.5 Volts peak to peak.

Output load: 150 Ohms \pm 10 %

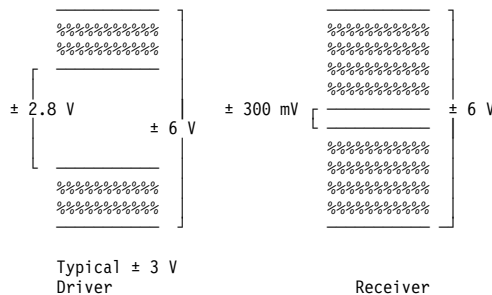

Chapter 5. AUI Ethernet Interface Cables

Both the office and standard access unit interface (AUI) Ethernet cables are provided by vendors and are not described in this document. The cable connectors must be equipped with a slide latch.

Warning:

1. All AUI Ethernet cables **must** conform to the ISO 8802-3.

ISO 8802-3

The connector is not specified to prevent operator contact with the shield, and precautions shall be taken at installation time to ensure that the installer is warned that the shield is not to be brought into contact with any hazardous voltage while being handled by operating personnel.

2. Before connecting the AUI Ethernet cables to the media access unit (MAU), you should be aware of the following notes:
 - a. The Ethernet feature's performances have been checked with a wide range of OEMs media access units. Although meeting the 802.3 standards, some MAUs are more sensitive than others to electromagnetic environment and may degrade the box performance related to the noise margin.
 - b. The MAU must be equipped with the SQE-TEST (also called HEARTBEAT) function.

ESS Wrap Plug PN 70X8670

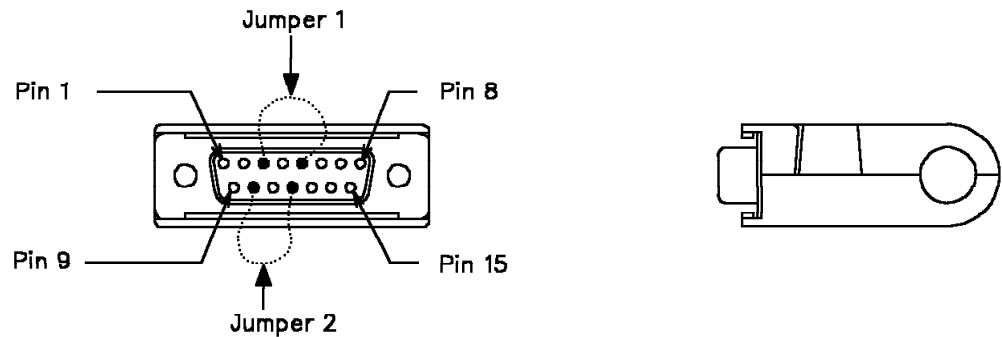

JUMPER	FROM	TO	DESCRIPTION
1	3	5	+TX to +RX
2	10	12	-TX to -RX

Chapter 6. Service Processor Cables for 3745 Models 21A, 31A, 41A, 61A, and 17A

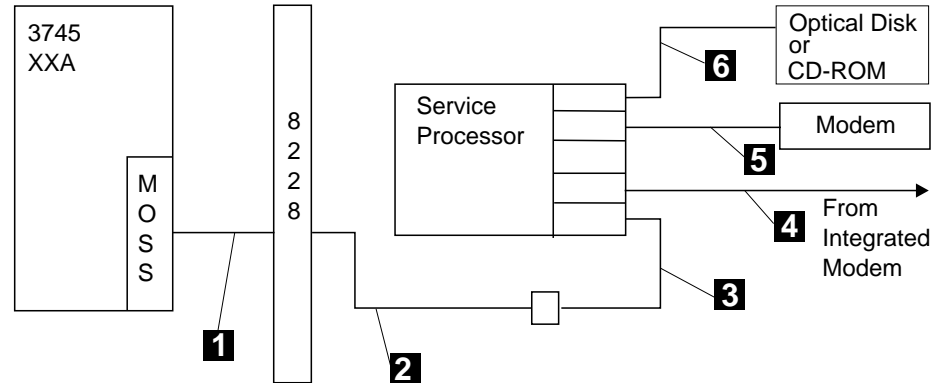

Figure 6-1. Service Processor Cables for 3745 Models xxA

Notes:

1. For cable **1**, refer to "Cable From any 3745 Model xxA to the 8228" on page 6-2.
2. For cable **2**, **3**, **4**, **5**, and **6** refer to the appropriate *Service Processor Installation and Maintenance* manual.

Cable From any 3745 Model xxA to the 8228

Refer to Figure 6-1 on page 6-1 reference **1** and Figure 6-2 for details.

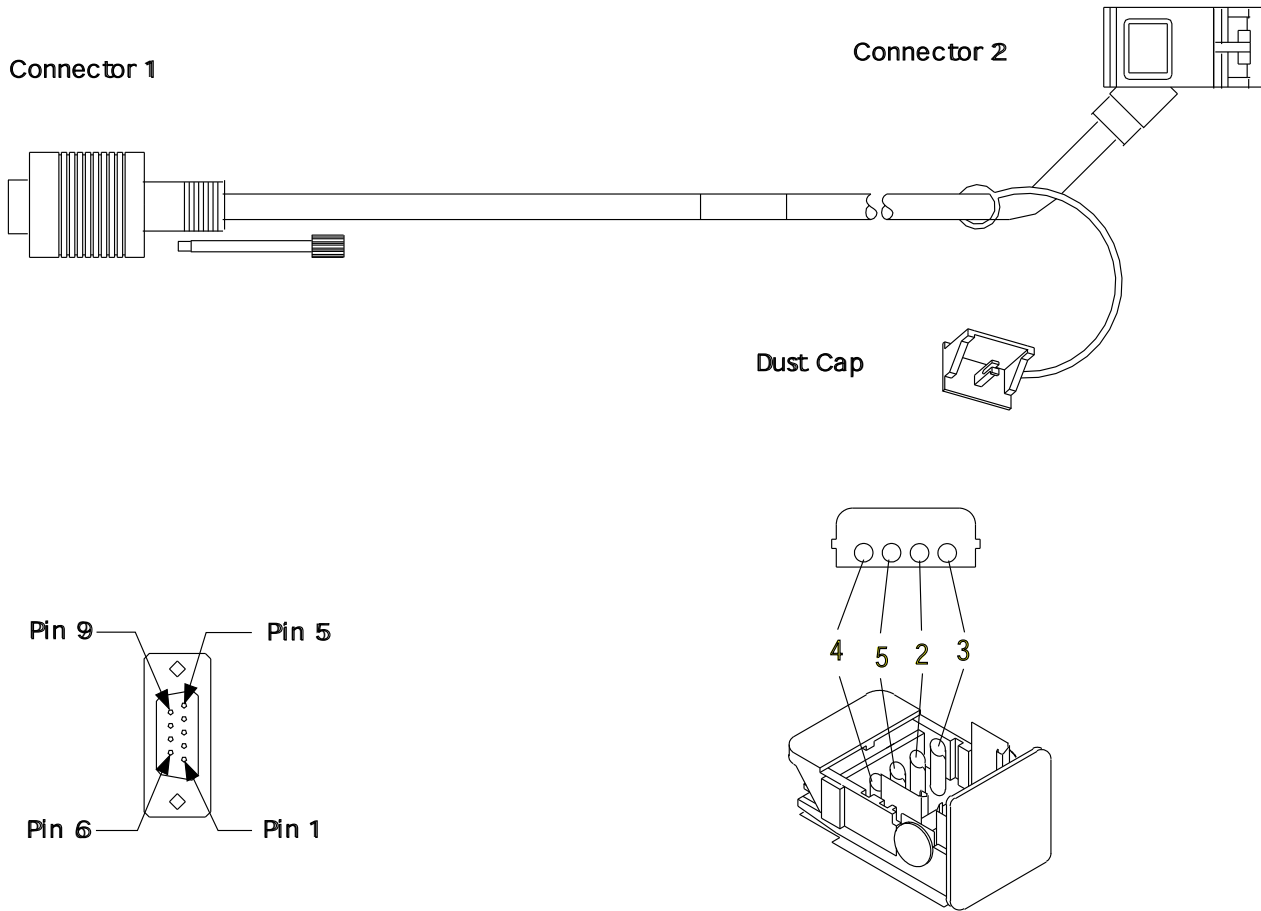

Figure 6-2. LAN Cable

Interchange Circuits

See “Interchange Circuit for Standard LAN Cable” on page 6-5.

<i>Table 6-1. Cable from a 3746-900 or any 3745 model A to a 8228</i>		
Cable Type	Length, m (ft)	Cable PN
Standard Fixed for World Trade	9 m (30)	76F9441
Standard Fixed for US only	9 m (30)	76F9440

Controller Expansion Grounding

When installed the controller expansion must be grounded to the premises grounding system using a ground wire provided by IBM.

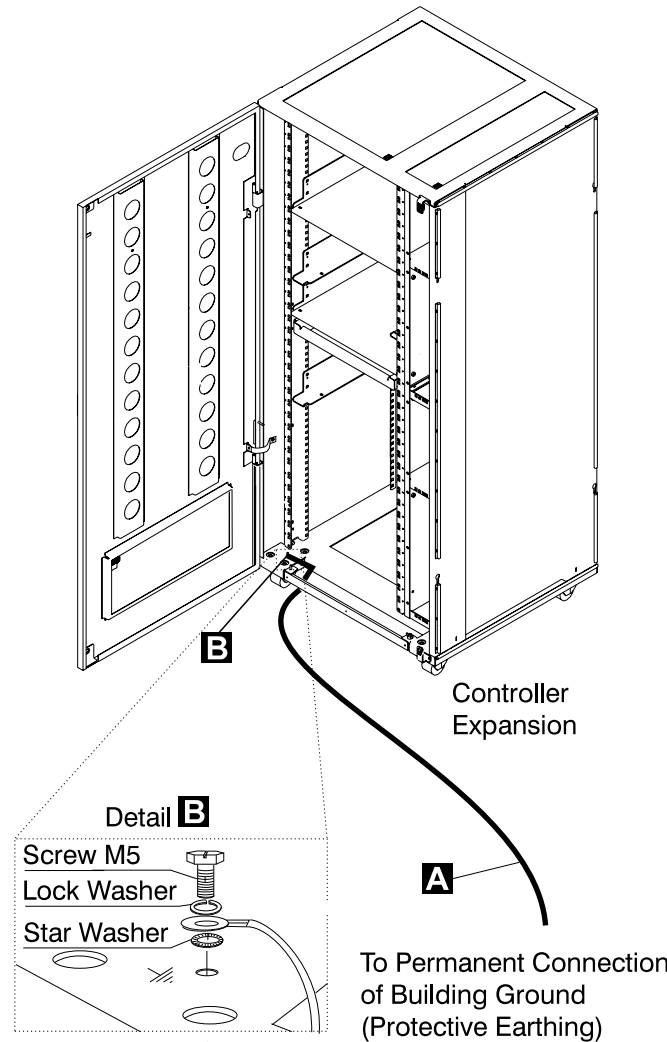

Figure 6-3. Ground Wire Connection on Controller Expansion

Table 6-2. Ground Wire for Controller Expansion		
Cable Type	Length	Cable PN
Standard Fixed A	9 m (30 ft.)	58G5691

B Screw PN 61F4513, star washer PN 1622347 or PN 17G5853, and lock washer PN 1622319.

Controller Expansion Unit Power Cables

Special power cables are provided to connect units installed in the controller expansion to the ac outlet distribution box.

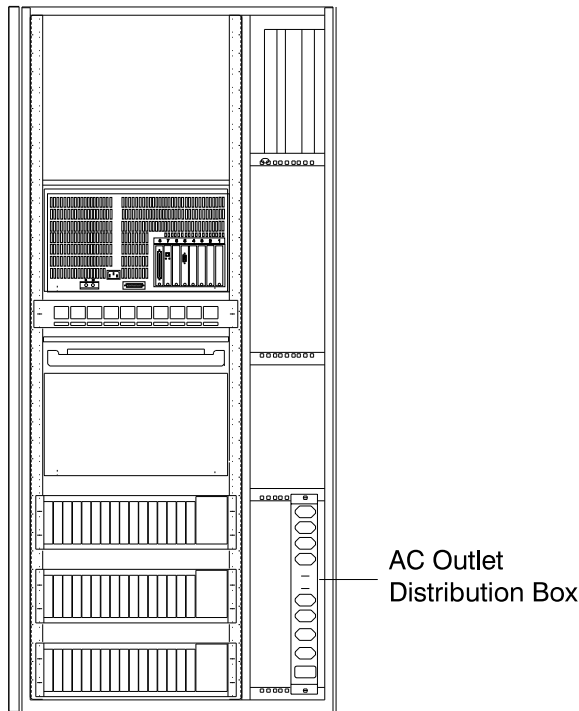

Figure 6-4. Controller Expansion ac Outlet Distribution Box.



Figure 6-5. Power Cable for Units Connected to the ac Outlet Distribution Box

<i>Table 6-3. Power Cable for Units Installed in the Controller Expansion Connected to the ac Outlet Distribution Box</i>		
Cable Type	Length	Cable PN
Standard Fixed	2.5 m (8 ft.)	58G5783

Local Area Network Cable

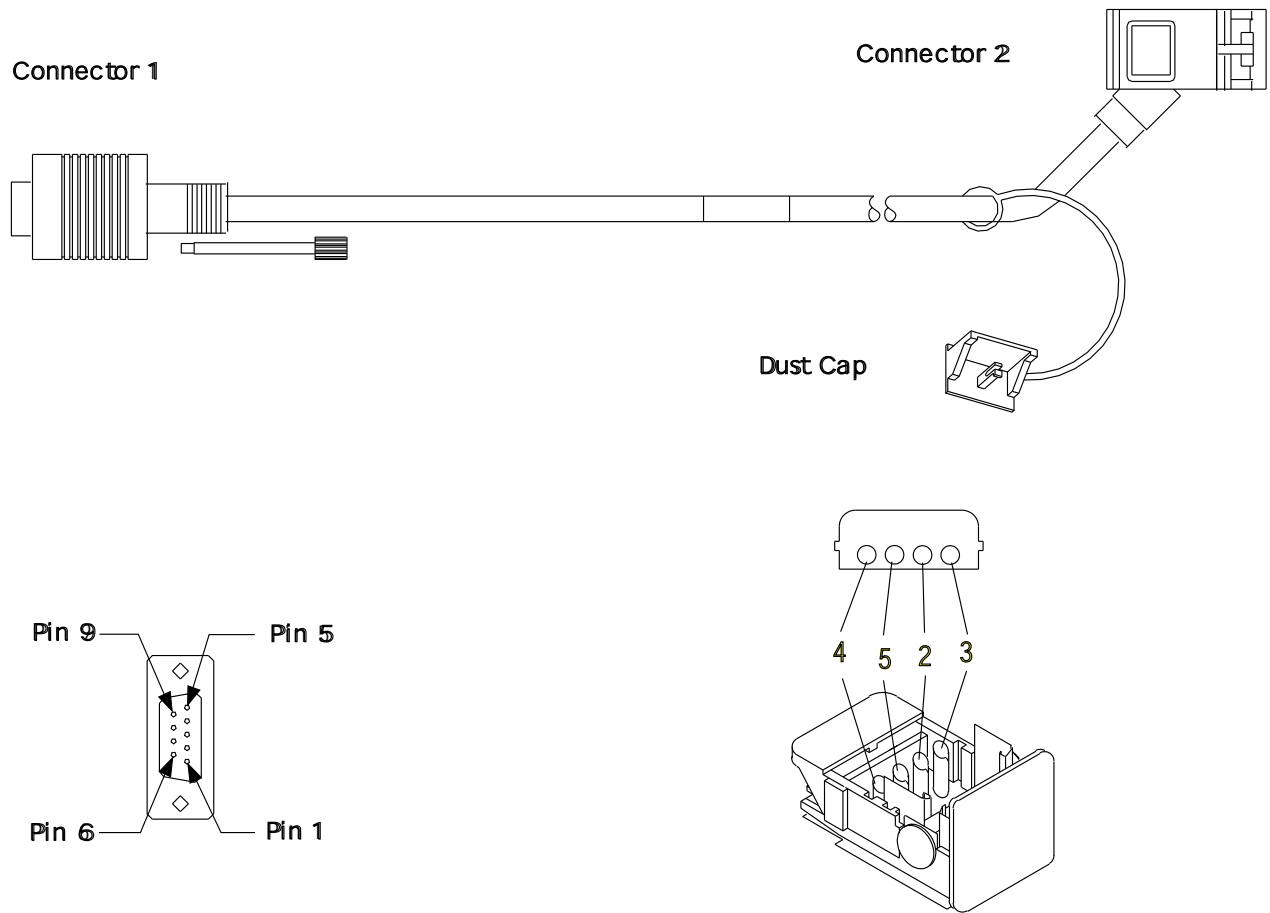

Figure 6-6. LAN Cable

Interchange Circuit for Standard LAN Cable

Table 6-4. LAN Cable Pin Assignment

Wire Nbr	Wire Color	Connector 1 Position	Connector 2 Position
1	SHIELD	GND	SHIELD
2	ORN	9	ORN
3	BLACK	5	BLACK
4	RED	1	RED
5	GREEN	6	GREEN

Table 6-5. Cable Length Ordering Information for EMEA

Cable PN	Feature Code	Length (Meters/Feet)
72F1236	5601	9/30 Fixed length
72F1236	5601	9/30 (max) Custom length
72F1236	5601	44/144 (max) Custom length

LAN Cable

<i>Table 6-6. Cable Length Ordering Information for U.S</i>		
Cable PN	Feature Code	Length (Meters/Feet)
72F1236	5601	22/70 Fixed length
72F1242	5601	22/70 Plenum Fixed length
72F1236	5601	22/70 (max) Custom length
72F1242	5601	22/70 (max) Plenum Custom length
72F1236	5601	44/144 (max) Custom length
72F1242	5601	44/144 (max) Plenum Custom length

Unshielded Twisted-Pair Cables

Twisted-Pair Connector Pin Assignment

This cable must use the 802.5 standard pin layout.

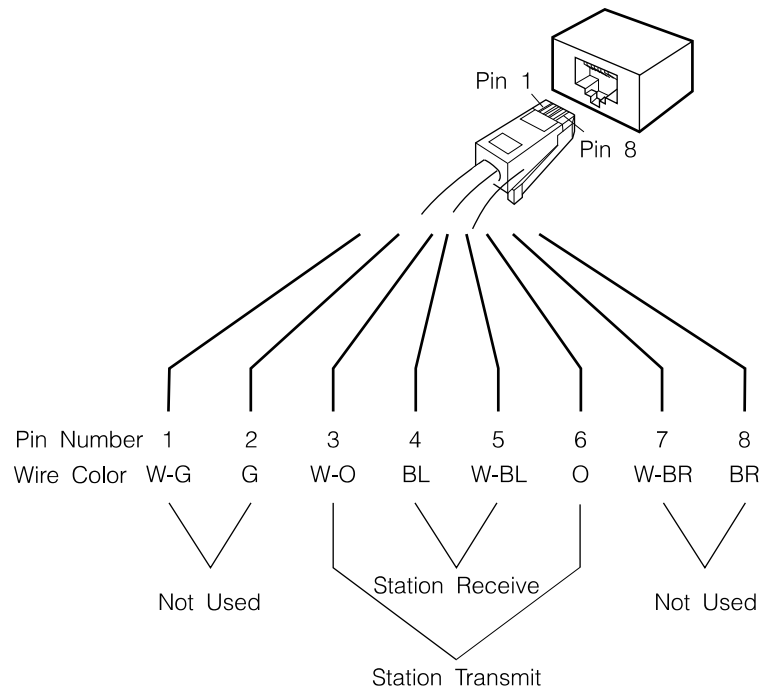

Figure 6-7. Twisted-Pair Connector

Token-Ring UTP Media Filter

The Token-Ring UTP media filter (PN 43G3875) links a 4 and 16Mbps token-ring network using UTP cabling.

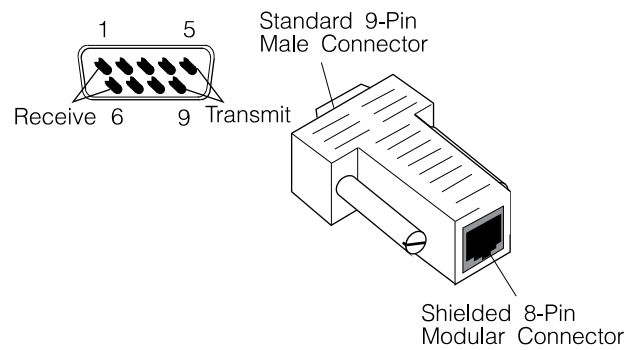

Figure 6-8. IBM Token-Ring UTP Media Filter (PN 43G3875)

UTP Cables

Appendix A. Bibliography

Customer Documentation for the IBM 3745 (Models 210, 310, 410, 610, 21A, 31A, 41A, and 61A), and 3746 (Model 900)







<p>Table A-1 (Page 1 of 4). Customer Documentation for the 3745 Models x10 and x1A, and 3746 Model 900</p>		
<p>This customer documentation has the following formats:</p>		
		
<p>Finding Information</p>		
<p>3745 Models A and 3746 Books</p>		
<p>Starting with engineering change (EC) F12380, all of the books in the 3745 Models A and 3746 library are available on the CD-ROM that contains the Licensed Internal Code (LIC) for this EC.</p>		
	<p>SA33-0172</p>	<p>IBM 3745 Communication Controller Models 210 to 61A IBM 3746 Expansion Unit Model 900 Customer Master Index¹</p> <p>Provides references for finding information in the customer documentation library.</p>
<p>Evaluating and Configuring</p>		
	<p>GA33-0092</p>	<p>IBM 3745 Communication Controller Models 210, 310, 410, and 610 Introduction</p> <p>Gives an introduction about the IBM Models 210 to 610 capabilities. For Models A refer to the <i>Overview</i>, GA33-0180.</p>
	<p>GA33-0180</p>	<p>IBM 3745 Communication Controller Models A² IBM 3746 Nways Multiprotocol Controller Models 900 and 950 Overview</p> <p>Gives an overview of connectivity capabilities within SNA, APPN, and IP networking.</p>

Table A-1 (Page 2 of 4). Customer Documentation for the 3745 Models x10 and x1A, and 3746 Model 900

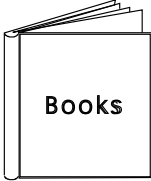
	GA33-0457	<p>IBM 3745 Communication Controller Models A² IBM 3746 Expansion Unit Model 900 Models 900 and 950</p>
<p>Planning Guide</p>		
<p>Planning for:</p>		
<ul style="list-style-type: none"> • Field upgrades • Service processor and alert management configuration • Network integration (NCP, APPN, and IP control) • Physical installation. 		
<p>Preparing Your Site</p>		
	GC22-7064	<p>IBM System/360, System/370, 4300 Processor Input/Output Equipment Installation Manual-Physical Planning (Including Technical News Letter GN22-5490)</p>
<p>Provides information for physical installation of the 3745 Models 130 to 610. For 3745 Models A and 3746 Model 900, refer to the <i>Planning Guide</i>, GA33-0457.</p>		
	GA33-0127	<p>IBM 3745 Communication Controller Models 210, 310, 410, and 610</p>
<p>Preparing for Connection</p>		
<p>Helps for preparing the 3745 Models 210 to 610 cable installation. For 3745 Models A refer to the <i>Connection and Integration Guide</i>, SA33-0129.</p>		
<p>Preparing for Operation</p>		
	GA33-0400	<p>IBM 3745 Communication Controller All Models³ IBM 3746 Nways Multiprotocol Controller Models 900 and 950</p>
<p>Safety Information¹</p>		
<p>Provides general safety guidelines.</p>		
	SA33-0129	<p>IBM 3745 Communication Controller All Models³ IBM 3746 Nways Multiprotocol Controller Model 900</p>
<p>Connection and Integration Guide¹</p>		
<p>Contains information for connecting hardware and integrating network of the 3745 and 3746-900 after installation.</p>		
	SA33-0416	<p>Line Interface Coupler Type 5 and Type 6 Portable Keypad Display</p>
<p>Migration and Integration Guide</p>		
<p>Contains information for moving and testing LIC types 5 and 6.</p>		

Table A-1 (Page 3 of 4). Customer Documentation for the 3745 Models x10 and x1A, and 3746 Model 900











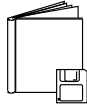

	SA33-0158	<p>IBM 3745 Communication Controller All Models³ IBM 3746 Nways Multiprotocol Controller Model 900 Console Setup Guide¹</p>
<p>Provides information for:</p> <ul style="list-style-type: none"> • Installing local, alternate, or remote consoles for 3745 Models 130 to 610 • Configuring user workstations to remotely control the service processor for 3745 Models A and 3746 Model 900 using: <ul style="list-style-type: none"> – DCAF program – Telnet Client program. 		
Customizing Your Control Program		
	SA33-0178	<p>Guide to Timed IPL and Rename Load Module</p>
<p>Provides VTAM procedures for:</p> <ul style="list-style-type: none"> • Scheduling an automatic reload of the 3745 • Getting 3745 load module changes transparent to the operations staff. 		
Operating and Testing		
	SA33-0098	<p>IBM 3745 Communication Controller All Models⁴ Basic Operations Guide¹</p>
<p>Provides instructions for daily routine operations on the 3745 Models 130 to 610.</p>		
	SA33-0177	<p>IBM 3745 Communication Controller Models A² IBM 3746 Nways Multiprotocol Controller Model 900 Basic Operations Guide¹</p>
<p>Provides instructions for daily routine operations on the 3745 Models 17A to 61A, and 3746 Model 900 operating as an SNA node (using NCP), APPN/HPR Network Node, and IP Router.</p>		
	SA33-0097	<p>IBM 3745 Communication Controller All Models³ Advanced Operations Guide¹</p>
<p>Provides instructions for advanced operations and testing, using the 3745 MOSS console.</p>		
	On-line Information	<p>Controller Configuration and Management Application</p>
<p>Provides a graphical user interface for configuring and managing a 3746 APPN/HPR Network Node and IP Router, and its resources. Is also available as a stand-alone application, using an OS/2 workstation. Defines and explains all the 3746 network node and IP configuration parameters through its on-line help.</p>		

Table A-1 (Page 4 of 4). Customer Documentation for the 3745 Models x10 and x1A, and 3746 Model 900

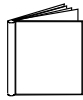
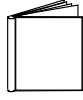
	SH11-3081	<p>IBM 3746 Nways Multiprotocol Controller Models 900 and 950</p> <p>Controller Configuration and Management: User's Guide⁵</p>
Explains how to use CCM and gives examples of the configuration process.		
Managing Problems		
	SA33-0096	<p>IBM 3745 Communication Controller All Models³</p> <p>Problem Determination Guide¹</p>
A guide to perform problem determination on the 3745 Models 130 to 61A.		
	On-line Information	<p>Problem Analysis Guide</p>
An on-line guide to analyze alarms, events, and control panel codes on:		
<ul style="list-style-type: none"> • IBM 3745 Communication Controller Models A² • IBM 3746 Nways Multiprotocol Controller Models 900 and 950. 		
	SA33-0175	<p>IBM 3745 Communication Controller Models A²</p> <p>IBM 3746 Expansion Unit Model 900</p> <p>IBM 3746 Nways Multiprotocol Controller Model 950</p> <p>Alert Reference Guide</p>
Provides information about events or errors reported by alerts for:		
<ul style="list-style-type: none"> • IBM 3745 Communication Controller Models A² • IBM 3746 Nways Multiprotocol Controller Models 900 and 950. 		
<p>¹ Documentation shipped with the 3745.</p> <p>² 3745 Models 17A to 61A.</p> <p>³ 3745 Models 130 to 61A.</p> <p>⁴ Except 3745 Models A.</p> <p>⁵ Documentation shipped with the 3746-900.</p>		

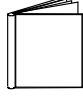
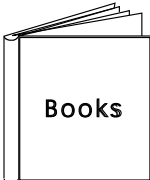
Additional Customer Documentation for the IBM 3745 Models 130, 150, 160, 170, and 17A

Table A-2. Additional Customer Documentation for the 3745 Models 1x0 and 17A		
This customer documentation has the following format:		
		
Finding Information		
	SA33-0142	<p>IBM 3745 Communication Controller Models 130, 150, 160, 170, and 17A IBM 3746 Expansion Unit Model 900</p> <p>Customer Master Index¹</p> <p>Provides references for finding information in the customer documentation library.</p>
Evaluating and Configuring		
	GA33-0138	<p>IBM 3745 Communication Controller Models 130, 150, and 170</p> <p>Introduction</p> <p>Gives an introduction about the IBM Models 130 to 170 capabilities, including Model 160.</p> <p>For Model 17A refer to the <i>Overview</i>, GA33-0180.</p>
Preparing Your Site		
	GA33-0140	<p>IBM 3745 Communication Controller Models 130, 150, 160, and 170</p> <p>Preparing for Connection</p> <p>Helps for preparing the 3745 Models 130 to 170 cable installation.</p> <p>For 3745 Model 17A refer to the <i>Connection and Integration Guide</i>, SA33-0129.</p>
<p>¹ Documentation shipped with the 3745.</p>		

Service Documentation for the IBM 3745 (Models 210, 21A, 310, 31A, 410, 41A, 610, and 61A), and 3746 (Model 900)

Table A-3 (Page 1 of 4). Service Documentation for the 3745 Models x10 and x1A, and 3746 Model 900

This service documentation has the following formats:

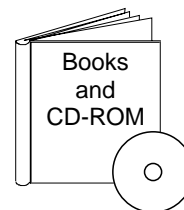







	SY33-2080	<p>IBM 3745 Communication Controller Models 210 to 61A</p> <p>Service Master Index¹</p> <p>Provides references for finding information in the IBM 3745 Models X10 and X1A shipping group documentation.</p>
	SY33-2057	<p>IBM 3745 Communication Controller Models 210 to 61A</p> <p>Installation Guide¹</p> <p>Provides instructions for installing or relocating the IBM 3745 Models X10 and X1A.</p>
	SY33-2114	<p>IBM 3746 Nways Multiprotocol Controller Model 900</p> <p>Installation Guide²</p> <p>Provides instructions for installing or relocating a 3746-900.</p>
	SY33-2116	<p>IBM 3746 Nways Multiprotocol Controller Model 900</p> <p>Service Guide²</p> <p>Provides procedures for isolating and fixing the IBM 3746-900 problems.</p>
	SY33-2055	<p>IBM 3745 Communication Controller Models 210, 310, 410, and 610</p> <p>IBM 3746 Expansion Units Models A11, A12, L13, L14, and L15</p> <p>Service Functions¹</p> <p>Describes MOSS functions using the IBM 3745 Models X10 and X1A consoles.</p>
	SY33-2054	<p>IBM 3745 Communication Controller Models 210 to 61A</p> <p>Maintenance Information Procedures¹</p> <p>Provides procedures for isolating and fixing the IBM 3745 Models X10 and X1A problems.</p>

Table A-3 (Page 2 of 4). Service Documentation for the 3745 Models x10 and x1A, and 3746 Model 900







	SY33-2115	<p>IBM 3745 Communication Controller Models A³ IBM 3746 Expansion Unit Model 900 IBM 3746 Nways Multiprotocol Controller Model 950</p> <p>Service Processor Installation and Maintenance⁴ (Based on the 7585, 3172, 9585, or 9577)</p>	
<p>Provides information on installing and maintaining the service processor based on PS/2 Types 7585, 3172, 9585, or 9577. Can be for systems with microcode that has up to and including EC D46130 (any level) installed.</p>		SY33-2120	<p>IBM 3745 Communication Controller Models A³ IBM 3746 Expansion Unit Model 900 IBM 3746 Nways Multiprotocol Controller Model 950</p> <p>Service Processor Installation and Maintenance⁴ (Based on the 7585, 3172, or 9585)</p>
<p>Provides information on installing and maintaining the service processor based on PS/2 Types 7585, 3172, or 9585. Can be for systems with microcode EC F12380 or higher installed.</p>		SY33-2118	<p>IBM 3746 Nways Multiprotocol Controller Models 900 and 950</p> <p>Multiaccess Enclosure Installation and Maintenance⁴</p>
<p>Provides information on installing and maintaining the Multiaccess Enclosure (MAE).</p>		SY33-2112	<p>IBM 3746 Nways Multiprotocol Controller Models 900 and 950</p> <p>Network Node Processor Installation and Maintenance⁴ (Based on the 7585 or 3172)</p>
<p>Provides information on installing and maintaining the network node processor based on the PS/2 Type 7585 or 3172.</p>		SY33-2056	<p>IBM 3745 Communication Controller Models 210 to 61A</p> <p>Maintenance Information Reference¹</p>
<p>Provides in-depth hardware reference information on the IBM 3745 Models X10 and X1A.</p>		SY33-2075	<p>IBM 3745 Communication Controller All Models⁵</p> <p>External Cable References¹</p>
<p>Provides references to console and line cables used for connecting the IBM 3745 Models 130 to 61A.</p>			

Table A-3 (Page 3 of 4). Service Documentation for the 3745 Models x10 and x1A, and 3746 Model 900



SY33-2117

**IBM 3746 Nways Multiprotocol Controller
Models 900 and 950**

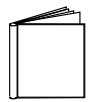
External Cable Reference⁶

Provides references to console and line cables used for connecting the IBM 3746 Models 900 and 950.

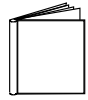

S135-2015

**IBM 3746 Nways Multiprotocol Controller
Models 900 and 950**

Parts Catalog⁶

Provides reference information for ordering parts for the IBM 3746 Models 900 and 950.

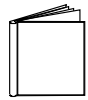

S135-2010

**IBM 3745 Communication Controller
Models 210 to 61A**

Parts Catalog¹

Provides reference information for ordering IBM 3745 Models X10 and X1A parts.



S135-2014

IBM Controller Expansion

Parts Catalog

Provides reference information for ordering parts for the controller expansion attached to the IBM 3745 Models A³, and 3746 Models 900 and 950.

Table A-3 (Page 4 of 4). Service Documentation for the 3745 Models x10 and x1A, and 3746 Model 900

CD-ROM Bibliography

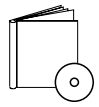

ZK2T-8214

**IBM Networking
Softcopy Collection Kit**

Allows service manuals consulting via CD-ROM viewer. EMEA version.

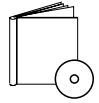

ZK2T-8187

**IBM Networking
Softcopy Collection Kit**

Allows service manuals consulting via CD-ROM viewer. US version.

- ¹ Documentation shipped with the 3745.
- ² Documentation shipped with the 3746-900.
- ³ 3745 Models 17A to 61A.
- ⁴ Documentation shipped with the processor.
- ⁵ 3745 Models 130 to 61A.
- ⁶ Documentation shipped with the 3746 Models 900 and 950.

Additional Service Documentation for the IBM 3745 Models 130, 150, 160, 170, and 17A

Table A-4. Additional Service Documentation for the 3745 Models 1x0 and 17A

This service documentation has the following formats:

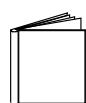
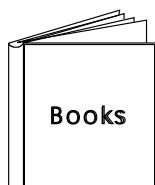

SY33-2079

**IBM 3745 Communication Controller
Models 130, 150, 160, 170, and 17A**

Service Master Index¹

Provides references for finding information in the IBM 3745 Models 1X0 and 17A shipping group documentation.

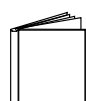

SY33-2067

**IBM 3745 Communication Controller
Models 130, 150, 160, 170, and 17A**

Installation Guide¹

Provides instructions for installing or relocating the IBM 3745 Models 1X0 and 17A.

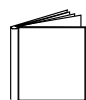

SY33-2069

**IBM 3745 Communication Controller
Models 130, 150, 160, and 170**

Service Functions¹

Describes MOSS functions using the IBM 3745 Models 1x0 and 17A consoles.

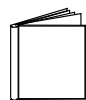

SY33-2070

**IBM 3745 Communication Controller
Models 130 to 17A**

Maintenance Information Procedures¹

Provides procedures for isolating and fixing the IBM 3745 Models 1X0 and 17A problems.

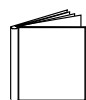

S135-2012

**IBM 3745 Communication Controller
Models 130 to 17A**

Parts Catalog¹

Provides reference information for ordering IBM 3745 Models 1X0 and 17A parts.

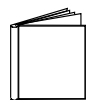

SY33-2066

**IBM 3745 Communication Controller
Models 130, 150, 160, and 170**

Hardware Maintenance Reference¹

Provides in-depth hardware reference information on the IBM 3745 Models 1X0 and 17A.

¹ Documentation shipped with the 3745.

List of Abbreviations

AUI	Access Unit Interface	LSS	low-speed scanner
BSC	binary synchronous communication	MAU	media access unit
CCITT	Consultative Committee on International Telegraph and Telephone	MOSS	maintenance and operator subsystem
CD	carrier detector (signal)	NCTE	network communication terminal equipment
CTS	clear to send (signal, same as RFS)	PC	personal computer
DCE	data-circuit-terminating equipment	PKD	portable keypad display
DCRLSD	data channel receive line signal detector (same as CD)	PT2/3	portable tool 2/3
DRS	data rate select (signal)	RD	receive data (signal)
DSR	data set ready (signal)	RFS	ready for sending (signal), same as CTS
DTE	data terminal equipment	RI	ring indicator (signal)
DTR	data terminal ready (signal)	RLSD	receive line signal detector
EIA	Electronic Industries Association	RPQ	request for price quotation
EMEA	European, Middle Eastern, and African countries	RSF	remote support facility
ESS	Ethernet subsystem	RLSD	receive line signal detector (same as CD)
FESH	front-end scanner (high-speed)	RTS	request to send (signal)
HPTSS	high-performance transmission subsystem	SDLC	synchronous data link control
HSS	high-speed scanner	TD	transmitted data (signal)
LIC	line interface coupler card	TI	test indicator (signal)
		TIC	token-ring interface coupler card
		TRSS	token-ring subsystem
		TSS	transmission subsystem

Index

A

- abbreviation list X-1
- adapters for consoles 1-4
- alternate console connection 1-3

C

- cable 6-3, 6-4
 - adapters for consoles 1-4
 - alternate console 1-3
 - connectors (DTE/DCE) for HSS 3-1
 - controller expansion grounding 6-3
 - controller expansion unit power cables 6-4
 - EIA-547 direct attach (HSS) 3-8
 - EIA-547 to DCE (HSS) 3-7
 - Ethernet interface cables 5-1
 - From the 3746-900 to the 8228 6-2
 - LAN cable 6-5
 - local console 1-1
 - ordering (DTE/DCE) 2-1
 - Service processor cables 6-1
 - TIC card to tailgate 4-1
 - TIC to token-ring 4-1
 - to ring wall connector (TRA) 4-2
 - Unshielded Twisted-Pair Cables 6-7
 - V.35
 - direct attach (HSS) 3-3
 - to DCE (HSS) 3-2
 - X.21
 - direct attach 3-6
 - to DCE (HSS) 3-4
 - to DCE (Transfix France), (HSS) 3-5
- console adapters 1-4
- console connection
 - 3745 to 7427 1-6
 - 7427 to 31XX or PS/2 or PC 1-7
 - 7427 to 3727 1-8
 - adapters 1-4
 - alternate console 1-3
 - local console 1-1
 - remote console 1-9
 - RSF modem 1-10
 - through 7427 1-6
- console wrap tools 1-12

D

- direct attach cable (V.35), (HSS) 3-3
- DTE/DCE cables connectors for HSS 3-1

E

- EIA-547
 - cable to DCE (HSS) 3-7
 - direct attach cable (HSS) 3-8

H

- HSS
 - cable to DCE 3-7
 - cable to DCE (Transfix France) 3-5
 - communication interfaces 3-1
 - direct attach cable 3-8
 - V.35 direct attach cable 3-3
 - V.35 interface to DCE 3-2
 - wrap plugs 3-10
 - X.21 interface to DCE 3-4

I

- interfaces of HSS 3-1

L

- LIC1
 - auto-call unit interface 2-7
 - DCE interface (except Japan) 2-2
 - DCE interface (Japan only) 2-4
 - direct attach interface 2-10
- LIC1 through LIC4 interfaces and cables 2-1—2-25
- LIC3
 - DCE interface 2-12
 - direct attach interface 2-14
- LIC4-A
 - DCE interface 2-16
 - direct attach interface 2-18
- LIC4-B
 - DCE interface 2-20
 - DCE interface (France Transfix only) 2-22
 - direct attach interface 2-24
- LIC5 and LIC6 interfaces and cables 2-26—2-28
- local console connection 1-1

O

- ordering DCE/DTE cables 2-1

P

- PKD Interface 2-30
- PT2/3 Interface 2-31

R

remote console connection 1-9
ring
 voltage levels (transmitter/receiver) 4-2
RSF modem cable 1-10

S

Service processor cables for 3745 models A 6-1
service processor connection
 Service processor connection 6-1

T

TIC
 interface cable to token-ring 4-1
token-ring
 TIC interface cable 4-1
TSS Interface Cables 2-1

V

V.35
 cable to DCE (HSS) 3-2
 direct attach cable (HSS) 3-3
voltage interface measurements (HSS) 3-9
voltage levels (TRA ring transmitter/receiver) 4-2
voltage levels (TSS driver/receiver) 2-32

W

wrap tools
 console/RSF 1-12
 ESS wrap plug 5-1
 for LIC1 and LIC4 2-29
 for LIC3 2-29
 for LIC5 and LIC6 2-30
 HSS 3-10

X

X.21
 cable to DCE (HSS) 3-4
 cable to DCE (Transfix France), (HSS) 3-5
 direct attach cable (HSS) 3-6

Readers' Comments — We'd Like to Hear from You

**3745 Communication Controller
All Models
External Cable References**

Publication No. SY33-2075-12

Please send us your comments concerning this book. We will greatly appreciate them and will consider them for later releases of the present book.

If you prefer sending comments by FAX or electronically, use:

- FAX: 33 4 93 24 77 97
- E-mail: FRIBMQF5 at IBMMAIL
- IBM Internal Use: LGERCF at LGEPROFS
- Internet: rcf_lagaude@vnet.ibm.com

In advance, thank you.

Your comments:

Name

Address

Company or Organization

Phone No.



Fold and Tape

Please do not staple

Fold and Tape

PLACE
POSTAGE
STAMP
HERE

IBM France
Centre d'Etudes et Recherches
Service 0798 - BP 79
06610 La Gaude
France

Fold and Tape

Please do not staple

Fold and Tape



Part Number: 03F5240

Printed in Denmark by IBM Danmark A/S

